

Linear

The Report

Published by the Linear consortium (Eandis, EDF Luminus, EnergyVille (KU Leuven, VITO & imec), fifthplay, iMinds, INFRAx, Laborelec, Miele Belgium, Proximus, Siemens, Telenet, Viessmann)
2014

www.linear-smartgrid.be
info@energyville.be

EnergyVille
Thor Park 8300-8490
3600 Genk
Belgium

To receive a hardcopy of this booklet, please send an e-mail to info@energyville.be.

All rights reserved. No part of this publication may be reproduced, stored in a retrieval system or transmitted in any form or by any means, whether electronic or mechanical, or by photocopying, recording or otherwise, without the prior consent of the project steering board (to be contacted via info@linear-smartgrid.be).

Editors in chief: Wim Cardinaels, Isabelle Borremans

Lay-out & graphics: Nathalie Belmans

Authors:

Ronnie Belmans, Bart Beusen, Bart Boesmans, Wim Cardinaels, Bert Claessens, Sven Claessens, Paul Coomans, Reinhilde D'hulst, Wim De Meyer, Jan Degraeve, Chris Develder, Benjamin Dupont, Wim Foubert, Jan Gordebeke, Felix Hoornaert, Sandro Iacovella, Johannes Jargstorf, Rafaël Jahn, Kris Kessels, Wouter Labeeuw, Philippe Muyters, Sven Penninck, Raf Ponnette, Daan Six, Steve Stoffels, Jeroen Stragier, Matthias Strobbe, Kris Van Daele, Philippe Van Dievel, Philippe Van Poppel, Donald Vanbeveren, Chris Vangrunderbeek, Koen Vanthournout, Gert Verbeek, Peter Verboven, Pieter Vingerhoets

Philippe Muyters

Flemish minister for Work, Economics, Innovation and Sports



I want to congratulate the Linear team for their excellent work.

Better use of energy is one of the biggest challenges our society faces today and in the years to come. This challenge requires the activation of all our knowledge and innovation power.

The Linear project is a guiding example on how to tackle these kind of overwhelming problems. In fact it did far more: it converted a societal challenge into a business opportunity.

The daily news shows the relevance of the niche on which Linear worked: make families adapt their electricity consumption to the availability of solar and wind energy, in such a way that their comfort is protected. Linear implemented solutions that help to get a robust energy system and in the same time contribute to achieve our targets concerning CO₂.

The realization of the Linear system was only possible because of the intense cooperation between research institutes and industry: Research explores unmarked routes, the industry knows the practical problems and constraints related to their activities.

The fact that ISGAN (International Smart Grid Action Network) nominated Linear as finalist out of more than 40 projects worldwide, confirms that in Flanders we are among the world leaders in this area.

Let us continue to valorize this excellent work to give a boast to Flanders and strengthen our economy.

Philippe Muyters

Flemish minister for Work, Economics, Innovation and Sports

Linear in Numbers >

400 kWp PV for 94 houses



75 smart grid controller prototypes for standard appliances



55 man time of use

funding 9,5 M€



1.5 Gb data per family

15 smart boiler prototypes



240 home energy management systems

110 smart meters



2,500 support tickets

almost 2000 families involved



1000 on-site interventions

2000 sub-metering plugs



20 partners



€30 M contributed by partners

5,000,000 readings per day

0101001

101101

011011

460 smart appliances



7 electrical vehicles



1500 questionnaires

185 smart homes



5.5 year: May 2009 – Dec. 2014

Linear: Research Moving Forward



We are very proud to present our Linear results. When we started in 2009, there were doubts about the relevance of investigating automated demand response systems for families. Logically, since we were preparing answers to the changing situations expected by 2020 and beyond.

In 2009, the boom of PV panels had not yet started, issues in low voltage grids were rare, we had a surplus of power plants, and gas plants were expected to be the answer to balance the variation in wind and solar energy.

Today, however, we are concerned about our energy supply for the coming winter. Half of our nuclear plants are out of order; natural gas plants have been closing en masse in recent years because their costs are not competitive in the current market design; coal-fired plants have been closed due to their high age; and, together with the renewables, the mix does not match the higher electricity demands during winter.

While the relevance of demand response for families was questionable in 2009, it is more relevant now than ever. The government and the electricity sector hope that families will reduce their consumption at the critical moments in the coming months in order to avoid the scenario in which we need to cut regions off from the grid.

Linear proved that automated residential demand response can mitigate the complications of the newly developing energy landscape. On the other hand, Linear also showed that technology and policy are not yet ready for a mass introduction of demand response business models toward families. Conclusion: the Linear research project has proven its value, but the end of the project is not the end of the smart grid challenges we're facing. It is only the beginning of new products and services that are going to change the energy landscape fundamentally.

Ronnie Belmans,

Chairman Linear Consortium
 CEO EnergyVille
 Executive Director Global Smart Grid Federation
 Professor at the KU Leuven
 Honorary chairman ELIA

Twenty partners have joined hands to support Linear >



Linear in Short

Linear is a Flemish Smart Grid project focusing on solutions to match residential electricity consumption with available wind and solar energy, an approach referred to as demand response.

Demand response is seen as an important smart grid technology which can help mitigate the effects of:

- the increasing share of intermittent renewable energy production in the mix;
- the increased electrical load due to the shift from fossil-fuel to electrical equipment;
- decreasing investments in directly-controllable (fossil-fuel) plants.

Although demand response is being increasingly deployed in the industry, the large potential of the residential sector has remained hitherto untapped since other criteria apply: comfort safeguards are a basic requirement to enable sustained participation of families in demand response schemes and the sources for flexibility are small as regards the quantity of energy but there are many of them. As such, the technology needed for residential demand response is fundamentally different from what is needed at the industrial level.

For Linear, partners from the research and industrial sectors joined forces in close collaboration with the government to develop, implement and evaluate demand response technology. Because of the **comfort requirements**, Linear selected and deployed 2 types of smart appliances that offer substantial flexibility and can be automated for a minimal impact on comfort. The first type consists of postponable appliances, such as dishwashers, washing machines and tumble dryers, 445 of which were deployed in the Linear pilot initiative. The second type consists of buffered appliances, of which Linear included 15 domestic hot water buffers and 7 electrical vehicles.

In the field test, 110 houses were equipped with smart meters. The other houses involved had standard energy meters for overall consumption and production. We installed approximately 2,000 sub-metering plugs, and 94 houses had photovoltaic panels accounting for a total of 400 kWp.

The Linear architecture supported different Home Energy Management Systems and Balancing Responsible Parties, thereby taking into account the **complex European deregulated energy market**. With standardized interfaces, appliances can exchange information and constraints in order to optimize system operation and user comfort.

The Linear system is a research platform designed and deployed by the partners to investigate user behavior and acceptance. For **4 business cases**, Linear also identified the technical and economic challenges and opportunities in facilitating an increased share of renewable energy sources.

The **4 business cases** selected were:

1. **Portfolio Management:** can we make customers shift their energy consumption based on the day-ahead market and nominations?
2. **Wind Balancing:** can we reduce unbalance costs for the retailer that are caused by discrepancies between the wind energy that is predicted and then actually produced?
3. **Transformer Aging:** can load spreading over time prevent the accelerated aging of transformers?
4. **Line Voltage Management:** can we prevent voltage deviation issues in local grids?

The Linear technology can be easily adopted by families and supports the operation of local distribution grids and energy markets. There were 240 families participating in the demonstration project, evaluating **2 different consumer interaction models**:

Variable Time of Use

We asked 55 families to alter their energy consumption based on different energy tariffs during the day (prices communicated the day before). We supported them with a Home Energy Monitoring System so as to give an insight into their consumption, and provided a display showing the market-priced tariffs scaled-up to the targeted wind and solar predictions in 2020.

Automated Demand-Side Management

Linear equipped 185 families with a Home Energy Management System and smart appliances, such as washing machine, dishwasher, tumble dryer, electric heating application and electrical vehicle, turning on the machines when more energy consumption was needed, or turning them off when less energy had to be used. All systems were of course equipped with features to manage the comfort of the users as well as ensure that the families could always take a hot shower and that the dishes would be ready when needed.

For each one, Linear investigated to what extent residential Demand Response could offer a technical and economical solution to mitigate the effects of the increasing share of intermittent renewable energy production, while still bearing in mind user behavior and comfort.

The response to the variable Time of Use tariff scheme was weak while the Linear tariff scheme turned out to be too complex. The acceptance of the smart-start functionality, however, was much better. After 18 months of testing there was still no indication of user fatigue, and the participants that stopped using the system did so because of technical issues.

The Linear field test demonstrated that automated demand response with household appliances is technical feasible. For each of the business cases Linear could improve the parameters controlled by the different algorithms. At the same time Linear showed that in-house communication should need further development and standardization in order to keep the operational cost affordable.

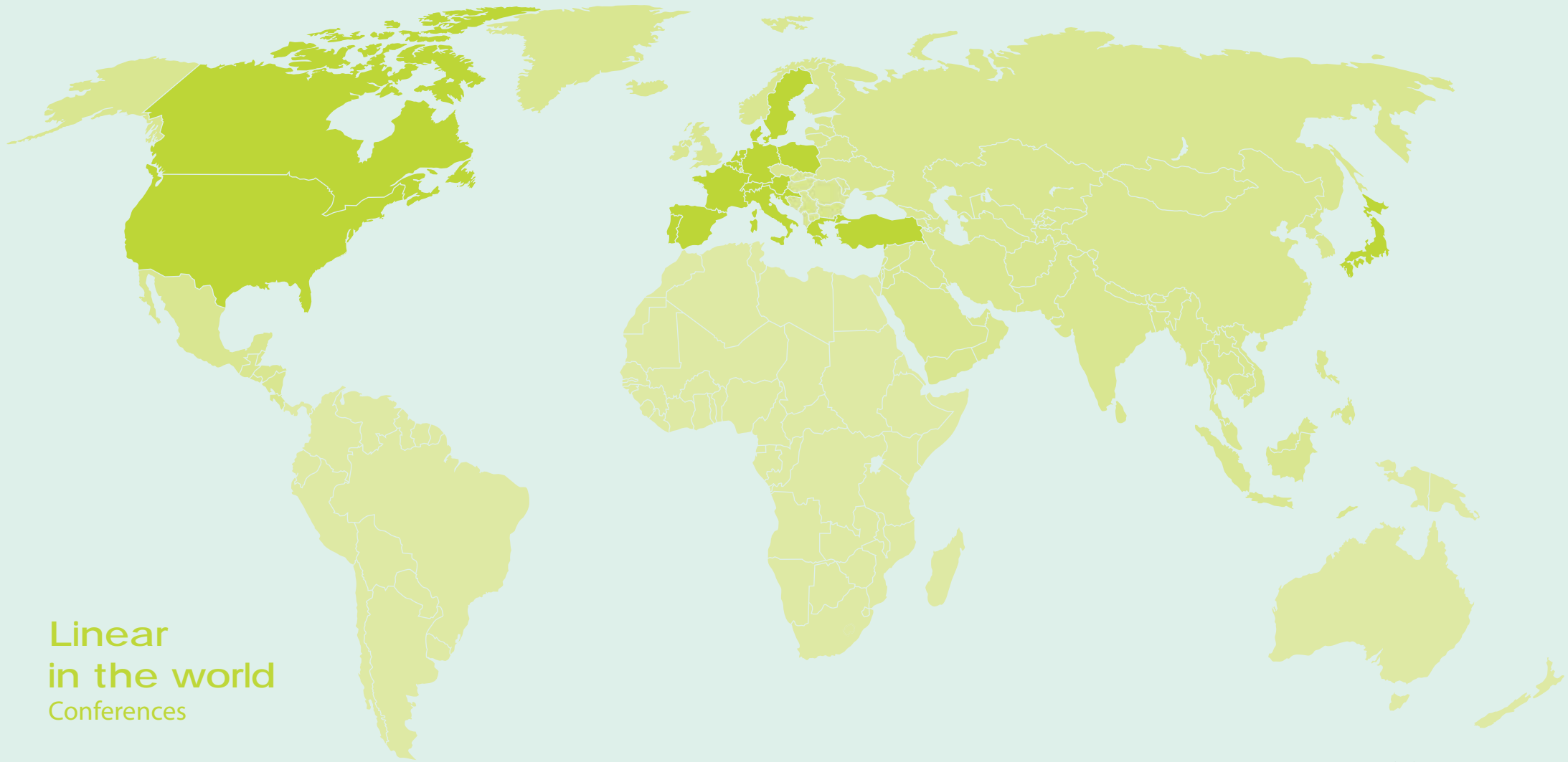

Linear in the world Conferences

- iMinds the Conference 2013, Brussel
- iMinds the Conference 2012, Brussel
- European Utility Week 2013, Amsterdam
- S3C Midterm Conference 2013, Evora
- SGParis 2014, Ghent
- IERE – GDF Suez Brussels Workshop, 2014
- Eurelectric Power Distribution Conference 2013, Brussels
- iSup 2012, Brugge
- ADDRESS 2nd Regional Belgian Workshop 2012, Brugge
- Innostock 2012, Lleida
- IEEE – PES ISGT 2012, Berlin
- IEEE - Smart Grid World Forum 2012, Geneva
- Symposium on Microgrids 2012, Evora
- IEEE Power & Energy Society General Meeting 2012, San Diego
- IECON 2013, Vienna
- IECON 2014, Dallas
- Innogrid 2012, Brussel
- ISGT 2013, Copenhagen
- Grid+ interaction event, Rome 2014
- CIRED 2011, Frankfurt
- EEM2011, Zagreb
- EEM2013, Stockholm
- CIRED 2011, Luik
- IRES2012, Berlin
- Sandia 2011
- SMIs 2nd annual distributed energy storage conference
- ICST conference on E-Energy 2010, Athens
- KIC InnoEnergy Scientist Conference 2012, Leuven
- PSCC 2014, Wroclaw
- smart grid comm 2014, Venice
- ISGT Europe 2014, Istanbul
- IM 2013, Gent
- SmartGridComm 2011, Brussel
- 2nd IEEE ICC International Workshop on Smart Grid Communications 2011, Kyoto
- NOMS 2010, Osaka
- Smart Grid Communications 2013, Vancouver
- EEDAL2011, Copenhagen
- SG Paris, 2014

Awards



S3C partner



ISGAN Award

Education



- BEST Summer School 2012, Leuven
- BEST Summer School 2013, Mol
- SGF Smart Grid School 2013, Brussel
- SGF Smart Grid School 2014, Brussel
- BEST Summer School 2014, Mol

Documentaries



- Alles kan schoner, 2013

Public Events



- SGF user group 2011
- SGF user group 2012
- Day for SMEs at Siemens, Huizingen 2013
- SGF PowerMatchingCity – Linear, 2013
- SGF Neighbors coming over 2014, Mollem
- Leuven city of ideas, 2014 Leuven
- SGF Grid Intelligence: Demand response 2014, Brussel

Publications



- EDF Sustainability Report 2012
- EDF Sustainability Report 2013
- Elektrovisie, Oct 2013
- VITO Vision, Sep 2013
- Milieu Direct, Dec 2013
- Bits & Chips, May 2014
- Power Pro
- Engineeringnet

Press



- VTM
- De Redactie
- TV Limburg
- Het Belang van Limburg
- Gazet van Antwerpen
- Het Nieuwsblad
- De Morgen
- Metro
- RTV
- Q-Music
- Radio 2

Table of contents

Transition towards a Decentralized Energy Supply	18		
In the Past: Centrally Managed	18		
Today: Decentralized Power Generation	18		
Preparation	22		
Families' Concerns About and Willingness to Adapt to Smart Appliances	22		
Electricity consumption of families	24		
Where to Find Flexibility?	25		
The Role of Energy Storage in Smart Grids	26		
Electrical Energy Storage	27		
Thermal Energy Storage	28		
Combined Heat and Power Systems as a Bridge between Gas and Electricity Networks	29		
Changing Conditions for Low-voltage Distribution Networks	30		
Integration of Renewable Energy into the Low-voltage Network	30		
Possibilities of Electric Vehicles for Smart Grids	33		
Driving Behavior Profiles	33		
Charging Electric Vehicles at Home	34		
Where Do We Go from Here?	35		
Simulations versus Real-life Tests	36		
Balancing	37		
Voltage Control	38		
A Combination of Business Cases?	39		
Wide-bandgap Power Technologies	40		
Real-life Deployment	46		
Technical Developments	46		
Smart Appliances	48		
Smart White Good Appliances	49		
Smart electric Domestic Hot Water Buffer	50		
Coordinated charging of electric vehicles	51		
ICT Architecture	52		
Measurements	56		
In-house equipment	60		
Test Families	63		
Recruitment	63		
Installation	67		
Remuneration Models	69		
Capacity Fee	69		
Dynamic tariffs	70		
Families: Lessons Learned	74		
Participant's concerns	74		
Flexibility offered by the participants	76		
Washing Machines, Dishwashers, Tumble Dryers	76		
Electric Hot Water Buffers	81		
Electric Vehicles	82		
		Impact on Security of Supply	85
		User Fatigue	86
		User Acceptance	88
		Business Cases	94
		Portfolio Management	94
		Linear Dynamic Tariff Scheme	95
		Manual Demand Response and Dynamic Tariffs	96
		Automated Demand Response and Dynamic Tariffs	97
		Wind Balancing	103
		Potential of Residential Demand Response for Intraday Balancing	104
		Linear Base Line Methodology	105
		Intraday Balancing Control	107
		Pilot Results	108
		Impact of Wind Balancing on the Low-voltage Grid	113
		Transformer Aging	114
		Setup and Control	115
		Pilot Results	117
		Line Voltage Control	120
		Regulatory Aspects	126
		Introduction	126
		Regulatory Framework	126
		Regulatory Challenges	127
		Market Roles	127
		Market Entry	127
		Regulation of Prices and Tariffs	128
		Remuneration of Grid Operators	128
		Privacy and Consumer Protection	129
		Standardization	129
		Scientific Publications	130
		Thank you	134
		Partners	
		Eandis	66
		EDF Luminus	19
		EnergyVille	47
		fifthplay	59
		iMinds	23
		INFRAx	55
		Laborelec	91
		Miele Belgium	58
		Proximus	62
		Telenet	43

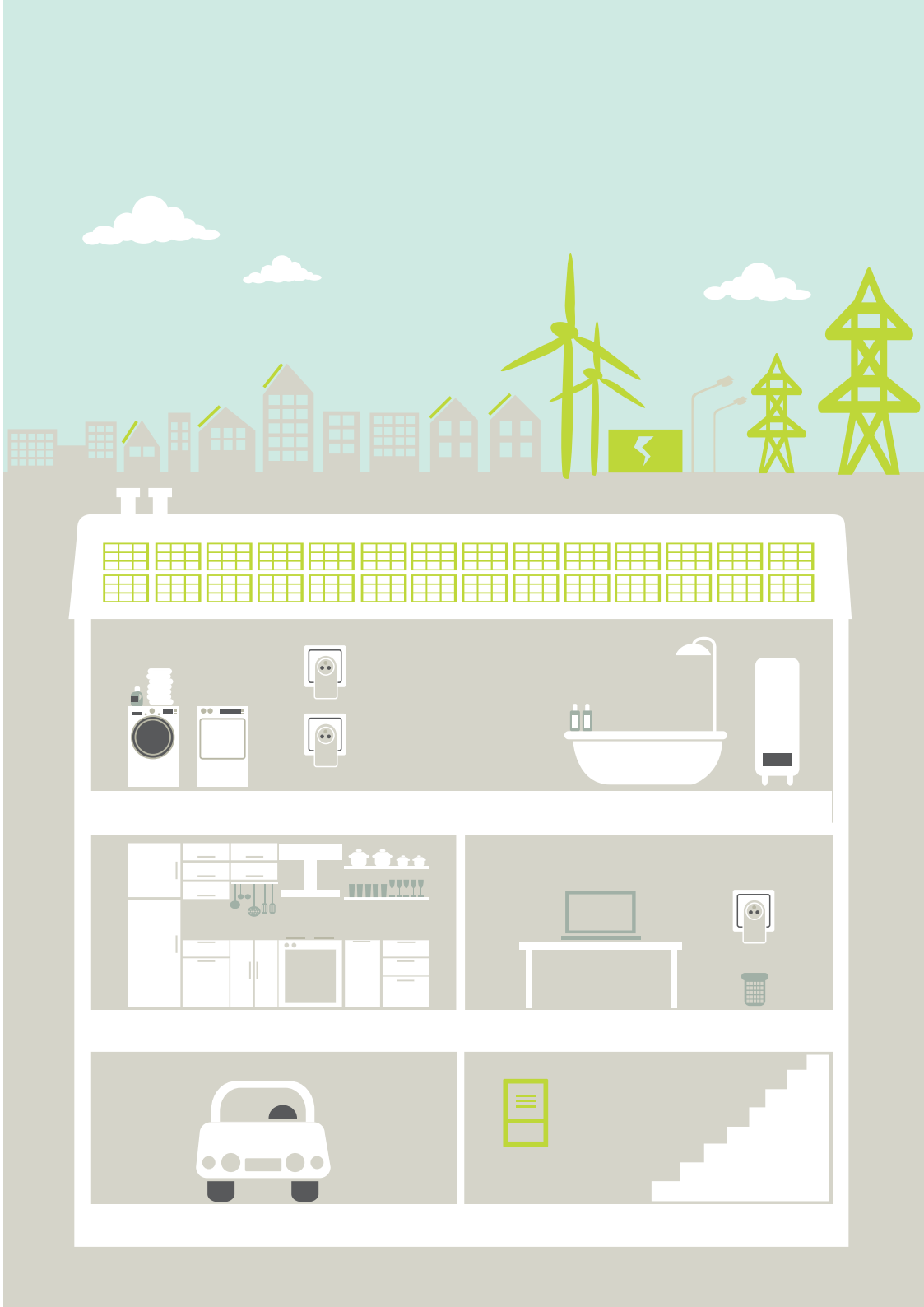

Transition towards a Decentralized Energy Supply

Transition towards a Decentralized Energy Supply

In the Past: Centrally Managed

In the previous century, electricity always flowed from a power plant to a substation via a transmission and distribution network, and then proceeded to houses and companies. Since traffic was one-way, it was fairly easy for transmission operators to maintain the network's balance using a centrally managed system.

Today: Decentralized Power Generation

In the last decade, we started installing wind turbines and photovoltaic systems throughout the country. Our target is to increase their share in the transition towards a CO₂-neutral energy system. These systems are set up in a decentralized manner, and they generate energy that is subject to the right weather conditions and regardless of the amount of power used on the network.

As long as the proportion of these sources of renewable energy is not too high, conventional power stations can absorb the variations in generation due to changes in sun and wind. But to integrate ever more renewable energy, solutions with regard to demand are needed. These could involve, for instance, removing surplus energy from the network and storing it in buffers, or matching power use with the available generation.

Electricity generation systems in Belgium



Today, Belgium has over 200,000 electricity generation systems, as opposed to just a few dozen a decade ago. As a result, electricity suppliers and network operators will have to work differently. The challenge is to completely redesign and adapt the electricity system, preferably in a way that will enable everyone to have access to power at all times and at a reasonable price.

Transmission operators are designing new products to be able to control the balance of their grids in these changing market conditions. Flexibility has become more important, and aggregators now generate business by harvesting flexibility in small and medium enterprises such as cold storage warehouses. These facilities can cool to lower temperatures when there is plenty of cheap energy, and then switch off their energy consumption for a few hours when energy is less readily available without affecting the shelf-life of the products stored.

In the Linear project, we researched the potential of demand response at household level.

EDF Luminus

Philippe Van Poppel, Director Strategy and Innovation



On the one hand, we see growing interest from a wider audience in changing behavior with regard to energy usage. On the other hand, we have learned that there is still a long road ahead in explaining active demand to a wider audience.

EDF Luminus can play an important educational role in improving the knowledge and interest of consumers. Broad interest in current energy topics, such as possible winter black outs, is a significant opportunity for making a link with active demand management.

The development of demand response services is encountering certain legal and regulatory hurdles, but it is mostly a matter of mindset and entrepreneurship. A clear ambition should be shared among stakeholders: Do we want customers and "prosumers" to actively participate in a competitive and "greening" energy market by empowering them to make their own choices regarding their comfort requirements, energy costs and privacy?

Only a commercially sound market model can live up to such expectations. Commercial parties should be able to offer their demand response solutions on a level playing field to consumers, energy companies and grid operators. Regulation, on the other hand, should incentivize and foster this new market, while nevertheless not creating new hurdles or market distortions.

A (smart) grid connects all stakeholders in such demand response solutions, and it is clear that no party can take single-sided action or decisions without impacting others. Only by involving and challenging each other in a good atmosphere of cooperation and competition can practical and well-balanced solutions be found to the benefit of everyone.



Preparation

Preparation

Families' Concerns About and Willingness to Adapt to Smart Appliances¹

In 2010, at the start of Linear, a face-to-face survey was carried out with 500 representative families in Flanders which were part of the Synthetic Load Profile² reference group. Part of this survey concerned the acceptance of, and expectations with regard to, smart appliances in a residential environment. Detailed explanations were given on the use and benefits of these appliances. Based on 9 dimensions (Figure 1) the respondents were categorized into 4 segments according to their attitude towards smart appliances. The segments were labeled 'Advocates' (36%), 'Supporters' (27%), 'Skeptics' (25%) and 'Refusers' (12%).

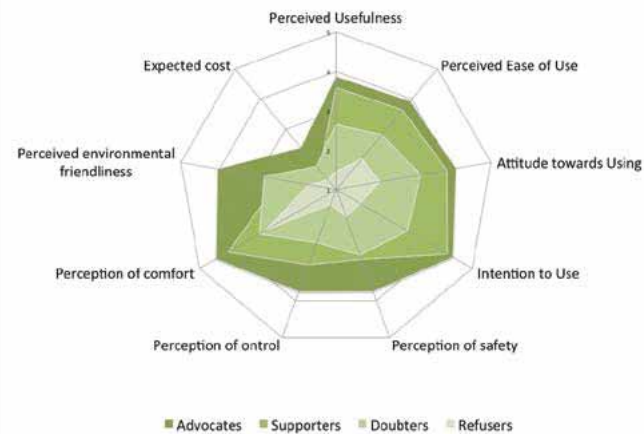

Figure 1: Attitude towards smart appliances among 500 Flemish Synthetic Load Profile families

The results of the segmentation showed diverging perceptions of smart household appliances in Flanders. Further profiling revealed a strong age difference between Advocates on the one hand, and Refusers on the other. Although it would be wrong to consider age as a determining factor for a negative perception of smart appliances, it can certainly be considered an important element.

Although the expected cost is a barrier, it is clear that a reasonable base of support exists for the use of smart appliances, as could be derived from dimensions measuring Perceived Usefulness, Attitude towards Using and Intention to Use. However, aspects such as control and safety revealed certain reservations. Even within the Supporters segment, which shows on average a positive perception, these two aspects seem to raise concerns.

¹ Stragier, J., Hauttekeete, L., De Marez, L., & Claessens, S. 2013. Towards More Energy Efficient Domestic Appliances? Measuring the Perception of Households on Smart Appliances. *Energy & Environment*, 24(5), 689-700.

² A curve or rating table per quarter or per hour of a full year that reflects the relative consumption for a certain type of customer. More info (in Dutch): www.vreg.be/verbruiksprofielen-0

iMinds Prof. Dr. Ir. Chris Develder

Current transitions in the energy landscape are a first step towards a (nearly) 100% sustainable society by 2050. Attaining that goal requires a substantial increase in the amount of renewable energy sources and storage facilities available on the grid, the further electrification of transport, industry and heating, as well as the more efficient use of available energy. Different solutions and technologies will be needed both to ensure security of supply with highly variable (and not directly controllable) energy production, and to upgrade the power grid in a cost-efficient manner. iMinds aims to contribute to the development of the ICT technology that will be an essential part of these solutions.



Within Linear, iMinds focused on the interconnection of a wide range of different systems and the real-time processing of the data received, and it also investigated user acceptance of residential demand-response services. Both subjects are essential to making this technology a successful part of solutions enabling a sustainable society.

The user studies showed that there is a great desire on the part of users to be truly involved, at least if they receive clear feedback on how their flexibility is used (along with the related financial rewards), and also that the user-friendly configuration of the appliances is key to including these services into people's daily routines.

Based on experiences within Linear, iMinds decided to build an actual house, rather than an artificial lab, to allow for the easy setup of truly realistic experiments with residential technology (communication, sensors, appliances and services). This home lab will be used for further research into automating the configuration of smart appliances while taking users' contexts into account, as well as in efforts to improve the reliability of in-home communication.

Furthermore, iMinds will continue its research into network and backend technology. The goal here is to transfer and process all generated data (consumption, production, flexibility, grid monitoring, etc.) so as to fully enable the optimal control of loads, production units, storage facilities and grid assets, as well as predict production, consumption and available flexibility.

Electricity consumption of families

Eandis and INFRAX delivered Linear electricity consumption data for analysis based on the energy consumption of 1,326 Flemish families and small businesses in 2008. A family's total electricity consumption on an annual basis varies from household to household. Most families have an electricity demand of between 2.8 and 3.3 MWh annually while median electricity demand is 3.6 MWh. On average demand is 4.9 MWh, which is high because a small group of households consumes a lot of electricity. (Figure 2)

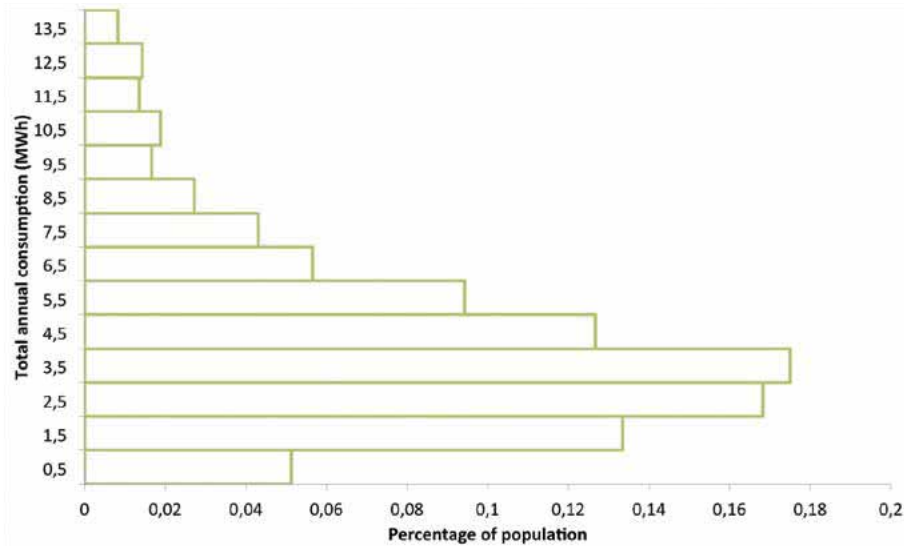

Figure 2: most prevalent electricity consumption of Flemish families and small businesses. Graph cut off at 14 MWh (maximum is around 200 MWh).

Electricity demand also varies during the day. Between 3 and 4 a.m. electricity demand is at its lowest, and there is a peak around noon and in the evening. To illustrate this, electricity demand during an average day of the year for households with median electricity demand (3.6 MWh) is presented in Figure 3, together with an estimation of how these households use wet appliances, i.e. washing machine, tumble dryer and dishwasher. Wet appliances are started at periods of high general electricity demand, showing potential to shift them to periods with lower demand.

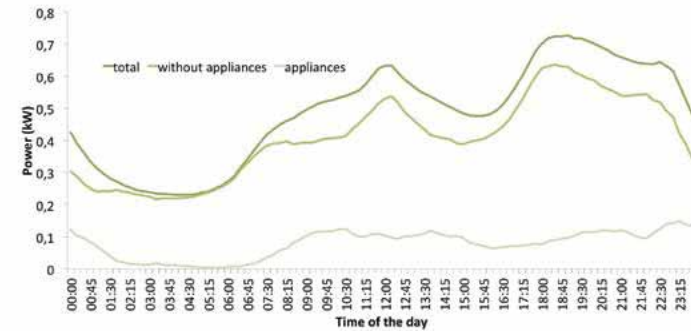

Figure 3: electricity demand during an average day of the year for a household with median electricity demand (3.6 MWh), together with an estimation of how the household uses wet appliances. such appliances are started at periods of high general electricity demand, showing potential to shift them to periods with lower demand.

Where to find flexibility?

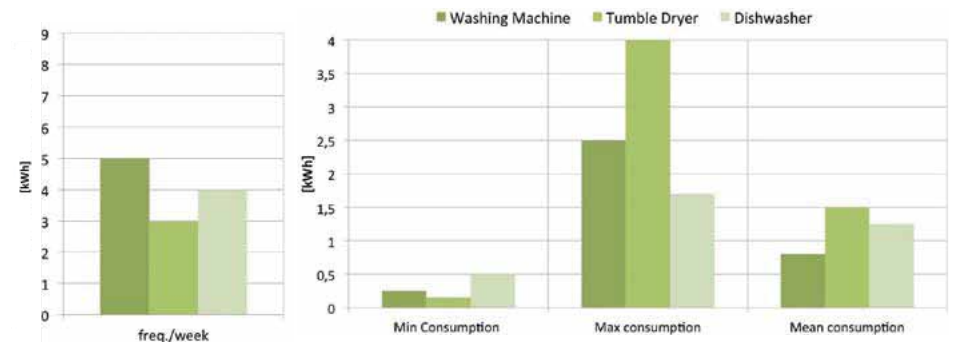
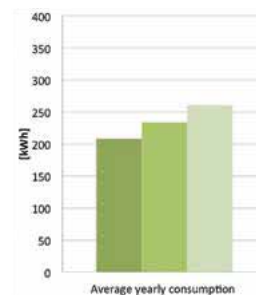

Figure 4: Usage and electricity consumption of household appliances per week



Demand response implies that the electricity **consumption of several appliances is shifted to a more beneficial moment in time**. The appliances need a certain amount of demand flexibility to change their energy use over time, and several options for offering such flexibility exist:

1. a **washing machine, dishwasher or tumble dryer** can delay starting as long as it finishes its cycle before a deadline defined by the user;
2. a domestic **electric hot water buffer** with thermal energy storage can decouple hot water demand from electric power demand through its thermal energy storage tank;
3. an **electric vehicle** can delay or interrupt its charging as long as the vehicle is fully charged before a deadline defined by the user.

The Role of Energy Storage in Smart Grids

Energy storage can play an important role in matching power generation with demand-side requirements at all times. Energy can be stored in different ways, and in this context Linear investigated the possibilities of storage applications for smart grids. Two main storage concepts served as the starting point for the analysis: storing electricity in batteries and storing heat in thermal buffers. For both main concepts we modelled, simulated and evaluated various potential practical implementations at both district and household level that involved centralized and decentralized variants (Figure 5). In the decentralized variant houses were assumed to be equipped with a battery system or an individual thermal buffer, while in the centralized variant the storage facility was not located in the house but rather in a separate, dedicated location in the district and operated by a utility company. For the thermal energy concept, the approach presupposed the presence of a heating network.

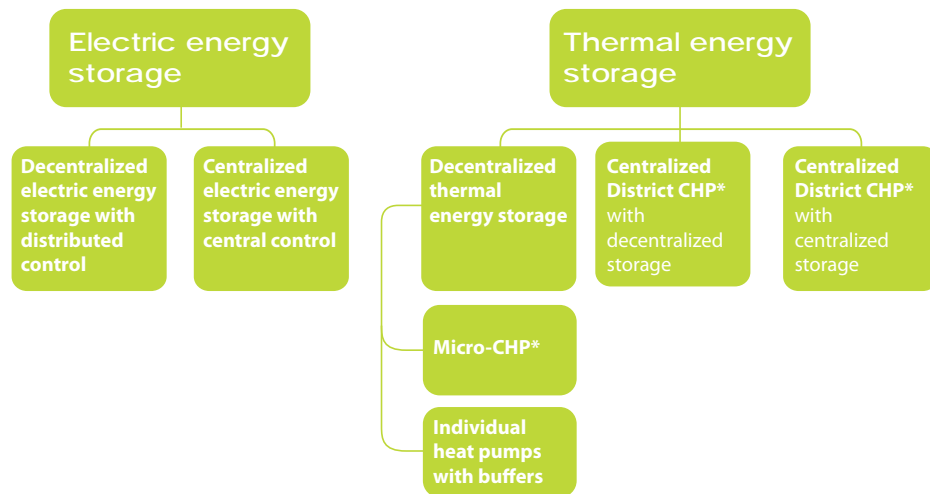

Figure 5: conceptual overview of the six different energy storage concepts for domestic and small commercial applications, investigated in the Linear project

Electric Energy Storage

Two key parameters determine the attractiveness of battery concepts: charging/discharging efficiency and depreciation cost per cycle.

Today, batteries and power electronics are still too expensive to be economically viable in smart grid applications. Whether or not a profitable situation can be attained depends primarily on two key parameters: charging/discharging efficiency and depreciation cost per cycle. In this connection, manufacturers expect energy density and sales volumes to increase by 2020, the result being significantly lower costs per kWh. On top of this, inverters and battery management systems still require further development and cost reductions. To improve the value of electrical energy storage for smart grid functionalities there is a need for more and better functionalities, such as reactive power control, islanding operation, interphase power exchange (balancing) capabilities, and state-of-health control. Before this type of storage can become a real business case, it needs to have these functionalities on the one hand, and a longer life span for the investment on the other.

* Combined Heat and Power Unit

Thermal Energy Storage

The thermal energy storage concept disconnects heat production from its use by storing energy in thermal buffers. Using a thermal buffer enables a heat pump to produce heat (and so consume electricity) at moments when there is a surplus of renewable electricity, either for immediate use for space heating and/or domestic hot water or for storage for later use in buildings or buffers. Furthermore, Combined Heat and Power units (CHP) implemented alongside a thermal buffer can generate electricity based on demand while either storing the heat or supplying it for direct use.

A centralized CHP for an entire district with centralized thermal energy storage offers the greatest flexibility potential, despite the fact that individual micro CHPs perform similarly (but are highly dependent on the specific heat profile of the house). Centralized CHPs for an entire district with decentralized buffers have the inherent disadvantage of a “weakest link situation” because the operation of the CHP is steered by the customer with the highest heat demand.

For the future massive implementation and continued operation of thermal energy storage concepts it will be crucial to have low-cost control systems, standard communication protocols and interfaces available commercially. Today, a thermal buffer is often a passive component integrated into the control system of the boiler, CHP or Heat Pump. In future scenarios, it is likely that a smart control device will steer the heating system and thermal buffer and decide which heat source is most appropriate based on current market conditions.

It should be noted that, next to purely technical developments, a modification of the regulatory and market framework will be important in creating the conditions necessary to stimulate the implementation and operation of smart energy storage concepts.

Combined Heat and Power Systems as a Bridge between Gas and Electricity Networks

What is the effect of Combined Heat and Power on the gas network? Research in the context of Linear presumed that all 300 injection nodes in a region in Hombeek-Leest would install a CHP system. As a result, we were able to observe a cost and CO₂ emission reduction of up to 30%. In simulations the pressure in the pipes was found to drop by up to 15 mbar, but the minimum pressure requirement of 23 mbar continued to be satisfied at all times. We can conclude that the massive integration of CHP presents no major concerns for the gas network.

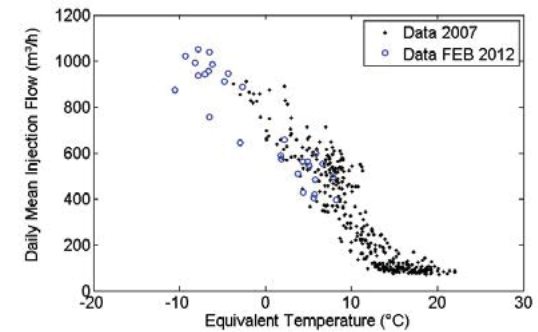

Figure 6: temperature-flow diagram for the Hombeek-Leest region
In February 2012 Flanders was facing the coldest weather conditions in decades

Changing Conditions for Low-voltage Distribution Networks

The increasing penetration of renewable energy, mainly generated by solar panels, is putting current low-voltage networks under stress and prompting distribution system operators to invest in costly upgrades of assets such as cables and transformers. For Linear, we carried out an investigation into the limits of these networks. First, four real-life networks were obtained from the partner distribution system operators to represent the low-voltage grid in Flanders. In a second step we investigated the limits of these networks with respect to increased loads and photovoltaic panels. In addition, the integration of Combined Heat and Power (CHP) systems and the relationship between electricity and gas networks were also studied.

Integration of Renewable Energy into the Low-voltage Network

Selection of the Most Relevant Networks

The Flemish distribution system operators INFRAX and Eandis made more than 30 different electricity distribution feeders available to Linear in the regions of Ghent, Diepenbeek and Hombeek-Leest. We categorized them into four representative groups: Rural, Semi-Urban, Urban and City. To represent each category we did not select the average feeder but instead the one most likely to face upgrades in the near future.

Semi Urban

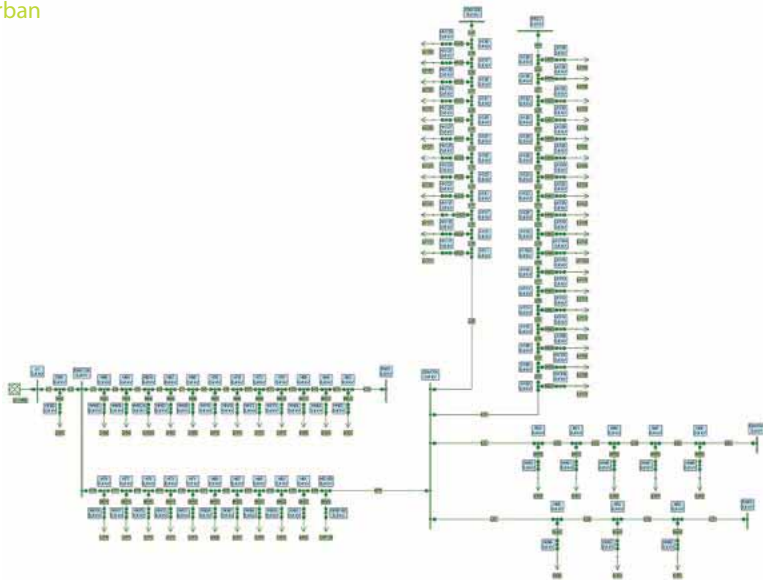

Urban

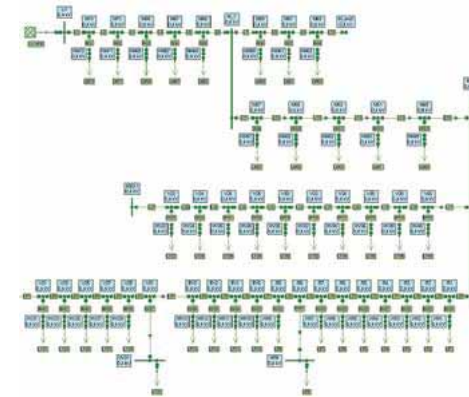

City

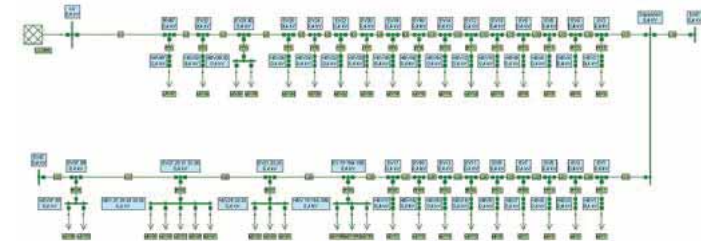

Rural

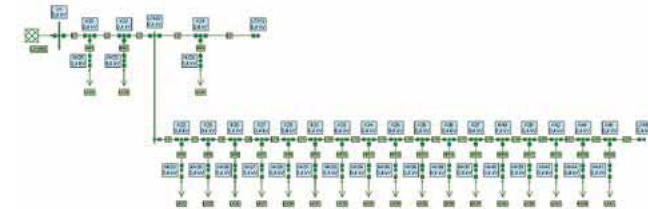

Possibilities of Electric Vehicles for Smart Grids

Integration of Renewables into Low-voltage Networks

For this research, we simulated the effect of photovoltaic power and increasing loads on the available networks. A Matlab load flow code was developed within Linear as it performed faster than commercially available software such as Neplan. More than 300 different scenarios were considered with different load profiles, different amounts of solar penetration, winter/summer day, distribution of PV panels/load among the phases, etc. For each of these scenarios we determined when the grid would need to be upgraded.

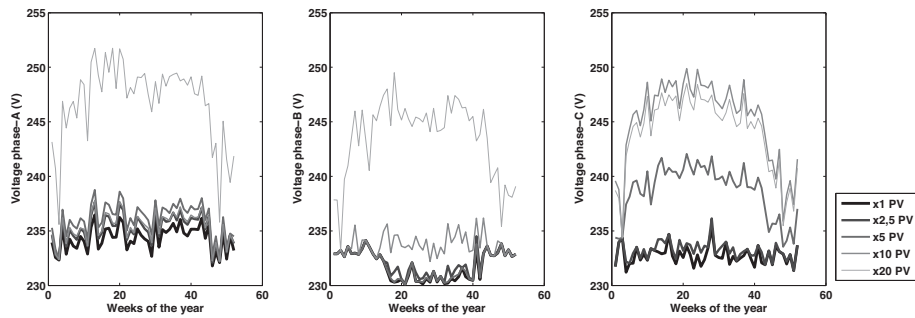

Figure 7: voltage/unbalance for the 3 phases of the urban feeder as a function of photovoltaic penetration

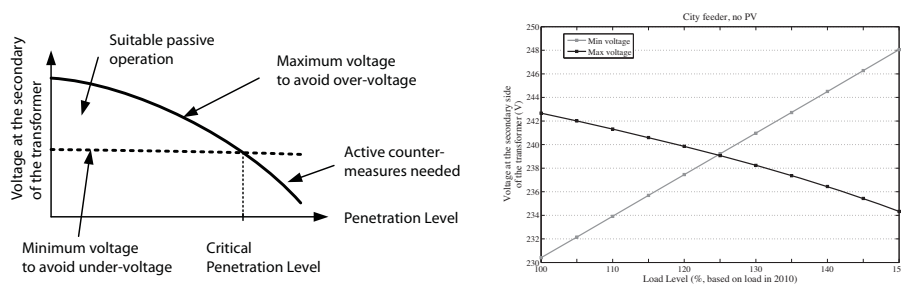
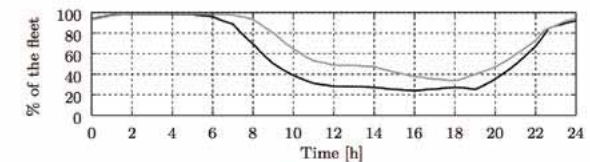

Figure 8: min/max voltage that can be set on the transformer to keep the feeder voltage within allowed limits. Grid upgrades become necessary at the crossover point.



Driving Behavior Profiles



(a) At home during week (black line) and weekend days (grey line).

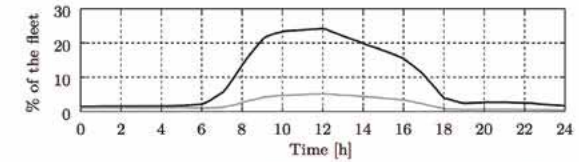

(b) At work during week (black line) and weekend days (grey line).

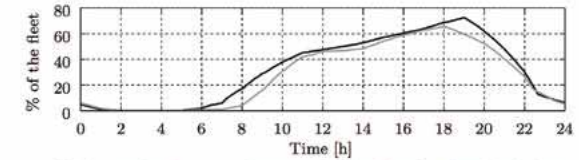

(c) At another location during week (black line) and weekend days (grey line).

In order to research the influence and interaction between a residential building and an electric vehicle, it is first necessary to have good insight into electric vehicles and their energy and capacity requirements in a distribution network under realistic conditions. This is why in Linear we set up a statistical vehicle availability model based on data from research into travel behavior in Flanders, vehicle segmentation in Flanders and an energy consumption model. We determined that on average fewer than 10% of all passenger cars are on the road at any given moment. Likewise, vehicles remain parked for longer (approximately 90% of the time) than the time that is necessary to recharge their battery. In fact, nearly all vehicles are parked at home overnight;

during the day, approximately 25% of cars are parked at home at any given moment. The possibility of charging at home is therefore an important element for electric vehicle users, and it lends relevance to research into minimizing the impact on the distribution network of numerous cars charging at home. We used this vehicle availability model to establish a realistic translation of the current mobility behavior into demand profiles for electric vehicles.

Charging Electric Vehicles at Home

With Linear we went in search of techniques that could reduce the undesired side effects of the charging process, such as a strong increase in peak capacity and voltage problems. These side effects were demonstrated beforehand using an extension of the distribution network simulations from Linear with the consumption profiles of electric vehicles.

This allows us to shift the charging processes over time in a coordinated manner so that the total demand on capacity from all charging processes and other loads is levelled off. If desired, the demand on capacity per building or per household can be levelled off. A benchmark and a multi-agent system were developed for charging coordination. The benchmark technique requires and has available all possible status information while the multi-agent technique only requires knowledge of the battery's charging status and the departure time indicated by the user. Both coordination techniques succeed in reducing the capacity peak. Although charging coordination does have a positive impact on voltage and imbalance issues on the three-phase distribution network, it cannot be guaranteed that such problems will be entirely prevented by these techniques.

This is why we researched the possibilities for a capacity reduction technique such as voltage droop control, which can be implemented on the chargers present in the vehicle. It manages to reduce the undervoltage problem, but cannot prevent the imbalance issue.

The combination of a multi-agent-based charging coordination system with a voltage droop control technique appears to be the most promising because not only are the capacity peaks levelled off, but the voltage issues are also solved, all with an extremely limited extension of the charging time per vehicle.

Where Do We Go from Here?

Linear can recommend that network operators determine whether electric vehicles are present in residential neighborhoods due to the strong local impact a few vehicles can have on certain distribution networks. A general and uniform approach for preventing potential problems is not recommended at this time because of the uncertainties that still exist concerning electric vehicle characteristics and the diversity of distribution network characteristics. We instead recommend setting up a "menu" from which the most effective solution can be selected depending on the context. Further follow-up on the evolution of the electric vehicle market and further research into changes in driver behavior (e.g. due to range anxiety) and into charging solutions are recommended in order to develop this menu of solutions.

Simulations versus Real-life Tests

Simulations offer the possibility to investigate new concepts via mathematical models. The only tools needed are a computer, software and a clever researcher, which means that the overall costs and risks are acceptable. On the other hand, the fact that a simulation environment only considers those aspects which have been modelled by the researcher is a shortcoming. As a result, when concepts are turned into real-life products a large number of unexpected interactions can ultimately influence performance.

For this reason, in Linear we decided to draw on both research techniques: we developed accurate models and sophisticated algorithms to investigate the impact of new control concepts, and then tested these concepts via prototypes in the Linear field test while subsequently using the findings to refine our models.

Flexibility provided by end-consumers can be used in several ways. For instance, it can provide an alternative to gas-fired power plants for correcting wind energy forecasting errors. Another possibility is deferring costly grid upgrades by controlling the voltage level on the grid. Simulations are a key instrument in assessing the potential of these concepts.

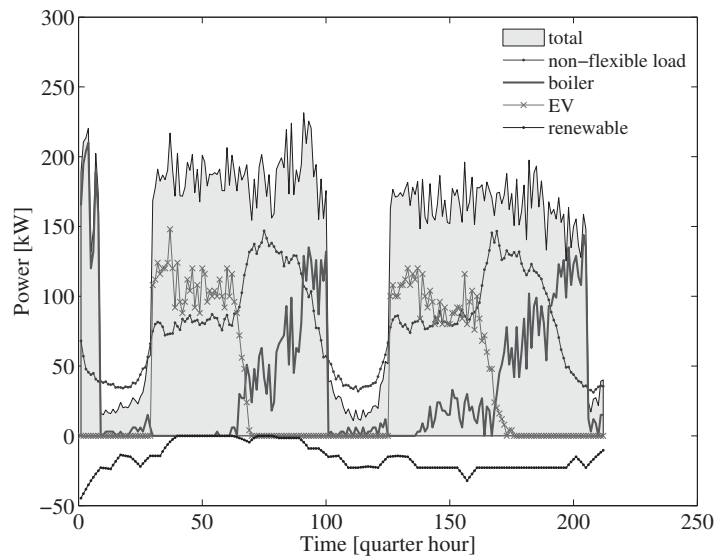

Figure 9: an algorithm with the objective to control the charging of an electric hot water boiler and electric vehicle to match the available renewable sources, taking the consumption of non-flexible loads into account.

Balancing

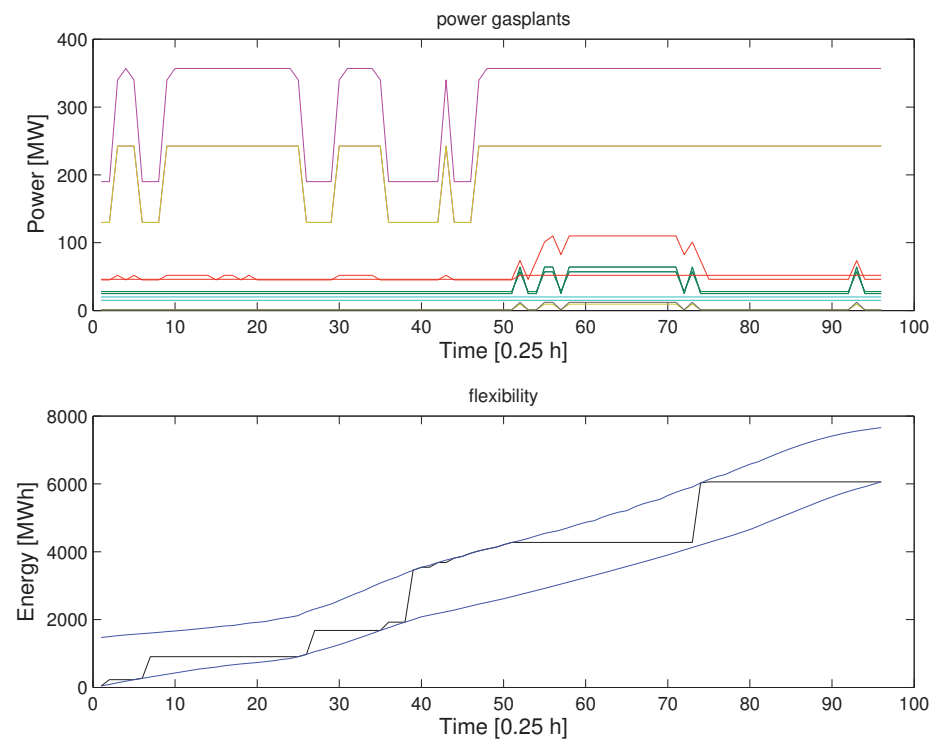

Figure 10: balancing using flexibility of smart appliances

Due to the unpredictability of solar and wind energy, production/consumption imbalances occur on the market. Traditionally, these imbalances have been removed by ramping up or down the electricity generation of gas-fired power plants.

Within the Linear project, a simulation code was developed to assess the potential of residential demand response as an alternative to gas-fired power plants. In Figure 10, the results show that activating or delaying consumption of smart appliances effectively reduces dependence on gas-fired power plants.

Voltage Control

The basic idea behind voltage control is simple: when voltage levels approach an upper limit additional consumption is activated, and when voltage levels approach a lower limit consumption is either switched off or delayed.

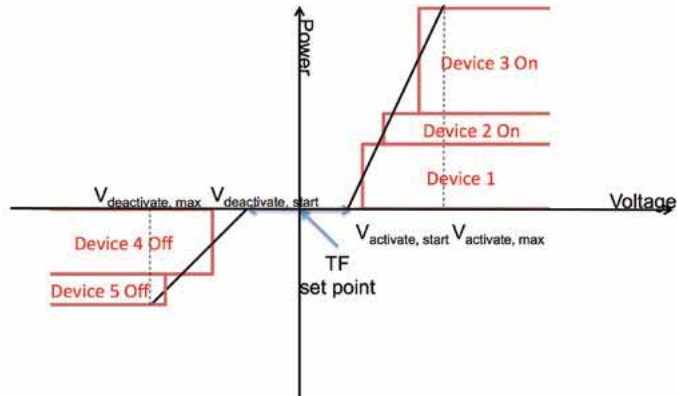

Figure 11: concept of voltage control

By configuring the entire low-voltage distribution network connected to a Linear transformer - including the smart appliances in the Linear houses - we were able to test our voltage control algorithm and optimize the parameters prior to activating this algorithm in real life in the field test. More than 150 scenarios were investigated: different feeders, summer/winter days, load profiles, smart appliances, voltage settings, etc. A maximum reduction of voltage problems in the field test compared to the reference case without voltage control was expected to be 30%.

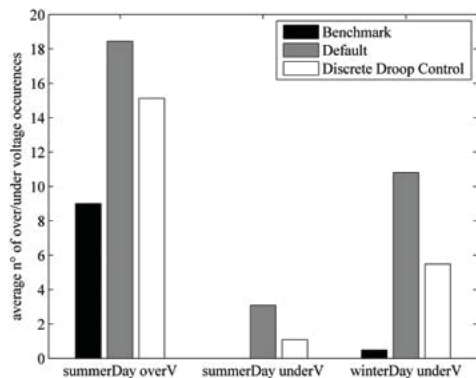

Figure 12: potential of voltage control during field trials for a summer and winter day

A Combination of Business Cases?

Linear considered it important to investigate how a distribution system operator can interact with the market when a retailer is steering flexibility.

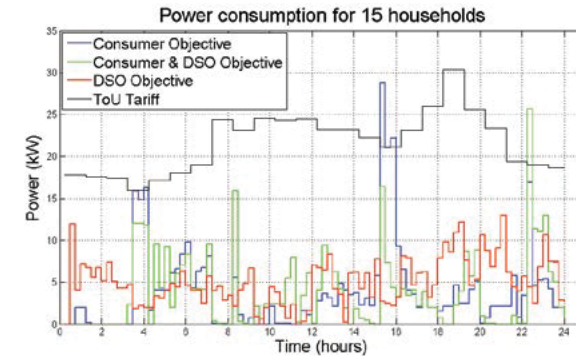

Figure 13: 15 smart households reacting to time-of-use prices combined with voltage control

We developed a simulation environment using a Linear distribution feeder with the same load profiles, households, photovoltaic injection, etc. (p.30 Changing Conditions for Low-voltage Distribution Networks) and combined the portfolio management and voltage control business cases. In a first scenario the objective of the households was to optimize their consumption by responding to Time-of-Use prices. In a second scenario the flexibility of household appliances was used to perform voltage control, while in a third scenario the constraints of both cases were taken into account to optimize both cost and line voltage. Figure 13 shows the different objectives during the day for 15 households.

When simulations were performed over two months, it was possible to calculate the economic benefits for the households and the extent of voltage problems for the distribution system operator in each of the three scenarios.

	OBJECTIVE			
	No control	Consumer	Distributed System Operator	Consumer + Distributed System Operator
Cost	230.6	208.5	225.7	209.1
#Voltage problems	942	633	593	588

Figure 14: cost vs. voltage problems for 15 smart households with smart appliances

Clearly, it can be concluded that voltage control has very little impact on cost reduction for consumers reacting to Time-of-Use prices. This means that, potentially, a combination of Time-of-Use and voltage control could be implemented without negative interference.

Wide-bandgap Power Technologies

In the electrical grid and residential networks of the future, increasing emphasis will be placed on the efficient management of electrical energy production, distribution and use. This will lead to the emergence of a smart grid, where electrical energy is intelligently controlled through a dynamic demand/supply model (e.g. by allowing household appliances to be controlled remotely) and distributed energy sources such as renewables can be seamlessly integrated into the network. Breakthroughs in this field are driven by developments in power electronics that relate to the efficient conversion, control and conditioning of electric energy from the source to the load. With respect to energy savings, using more efficient power electronics shows huge potential. Specifically, the quoted potential for energy savings is around 30%, which translates into a reduction of 11% of the EU's total energy usage. Within the framework of the Linear project, imec has carried out a study and established a roadmap for the development of future (wide-bandgap) power technologies.

Switching power converters and inverters are key components in power electronics. They allow the efficient conversion of electrical energy from one form into another, e.g. they step up the voltage for energy distribution, step in between supply voltage and operational voltage in a consumer device, convert AC to DC from the socket to an appliance, convert DC to AC to deliver energy from solar panels to the grid, etc.

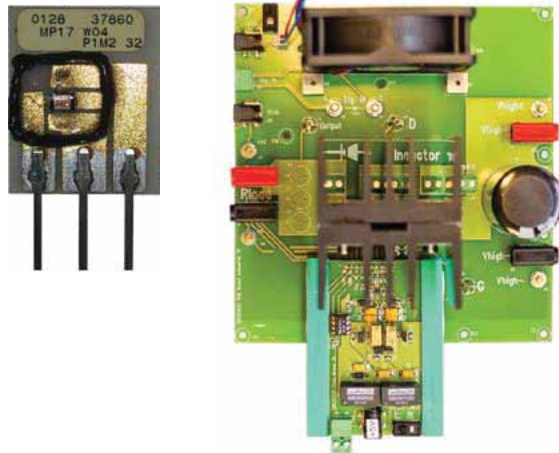

Figure 15 - example of a gallium-nitride based switching power converter prototype and (right) a gallium-nitride power transistor produced by imec in a prototype-to-220-like package.

At the heart of these power converters one can find a switching semiconductor component which is in large part responsible for determining their characteristics. An ideal switching device should have zero resistance when turned on and infinite resistance when turned off (without failing), and also ideally should switch instantaneously between the on and off mode. A real-world device of course does not exhibit these perfect characteristics, and research in the field has focused on improving them so as to develop better switches which can handle higher blocking voltages, as well as higher currents, and which can switch at higher frequencies.

As such, these power semiconductor devices place limits on achievable power efficiency, switching speed and size limit for various power conversion topologies. Accordingly, it is important to have a critical look at these power components, their historical development and future evolution.

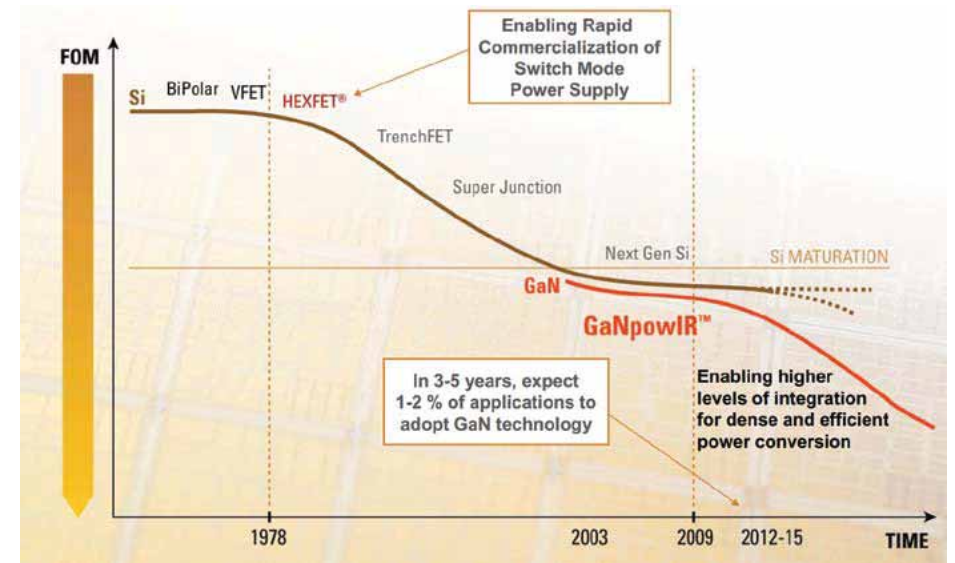

Figure 16 - evolution of power transistor figures of merit over the past 30 years along with the projected evolution of gallium-nitride (GaN) power devices².

¹ Catrene Scientific Committee Working Group: Integrated power & energy efficiency, "Integrated power & energy efficiency: Power device technologies, simulations, assembly and circuit topographies enabling high energy efficiency applications". Catrene, April 2013

² McDonald, 2009. GaN Based Power Technology Stimulates revolution in Conversion Electronics (International Rectifier).

For the past fifty years silicon has been the material of choice for fabricating power devices, and incredible gains have been made in power transistor figures of merit through technology optimization, improved manufacturing techniques and novel architectures. However, in the past decade progress has slowed as silicon reaches a high level of technology maturation, meaning that it is becoming very costly to only marginally improve the technology's performance. In fact, figures of merit have reached values close to the limits dictated by the material. For this reason, researchers have started turning to novel materials. The main contenders to follow up silicon-based materials as the dominant power technology are silicon-carbide-based power components and gallium-nitride-based transistors. These materials have much-improved intrinsic properties and associated figures of merit for use in power switching devices. In this connection it is worthwhile to note that first-generation devices already show figures of merit exceeding those for state-of-the-art silicon devices, with moreover the promise of rapid evolution in fabrication technology and therefore figures of merit.

With regard to residential networks, these novel wide-bandgap materials are going to have a big impact on how efficiently energy is used. Gallium-nitride technology can as such play a critical role in the smart grids and smart homes of the future. It is a breakthrough technology allowing for a significant reduction in energy losses in power switching convertors as compared to established silicon technologies. Initially, the target market will be that of medium-power devices found in residential settings, so for example power supplies for home appliances, computers, television sets, tablet computers, chargers for electrical vehicles, etc. The distribution side of the smart grid requires voltages of several kV and above, and currently silicon-carbide technology is more suited to these ranges. However, developments in high-voltage gallium-nitride vertical devices are on-going, with the promise of outperforming silicon-carbide with respect to achievable figures of merit.

Telenet

Jan Degraeve, VP Sustainability & Corporate Office

Energy consumption in Flanders continues to rise every day, and increasingly a portion of the required energy is being generated locally. Solar panels, wind power and heat pumps provide the means for generating renewable energy, part of which can be injected back into the network by smaller, domestic players.



Telenet is working together with Distribution Network Operator Eandis on a pilot project involving smart meters in the area around Mechelen. In this context 3,000 households have been equipped with smart meters, including a few participants in the Linear field tests.

Smart grids, or smart energy networks, go yet a step further than smart meters. Smart networks are necessary because there are large-scale, renewable but fluctuating energy sources that need to be linked to them, and new developments, like electric cars, need them to function efficiently. This is why Telenet is taking part in Linear and focusing, through the Smart E Project, on the smart data flows that are necessary to the implementation of the system and that are made possible through an intricate and high-performance communication network.

Participation in Linear and the Eandis smart meter project fits in with the many initiatives Telenet takes to reduce energy consumption among its consumers, such as the set-top box and more efficient internet modems.



Real-life Deployment

Real-life Deployment

Technical Developments



Figure 17: EnergyVille Home Lab

Right from the start, the Linear pilot had high technical ambitions. The Linear infrastructure supported multiple business/control cases as well as different types of smart appliances from multiple vendors. Moreover, detailed measurements were carried out to support the various analyses. As smart appliances are not yet widely available, in addition to integrating appliances with onboard smart grid functionality Linear converted standard appliances, such as domestic hot water buffers and white good items, to smart devices.

On the electricity grid side, the Linear system incorporated two types of smart meters. In Hombeek and Leest, and in Bret-Gelieren, so those areas with strong Linear participant concentrations (9.2.1. Recruitment), Linear also collected transformer measurements.

To support the development and testing of the prototypes and to test the integration of all components into the Linear infrastructure, several labs were constructed, among which the EnergyVille Home Lab and the Laborelec Smart Home Energy Lab.



Figure 18: Laborelec Smart Home Energy Lab (shel)

EnergyVille

Peter Verboven, Business Developer



Research & Development centers such as EnergyVille tend to operate several years ahead of the market. We are continuously developing concepts, technologies, solutions and systems that will subsequently have to find their way into our everyday lives. A lot of this work is done through simulations, in labs or in other controlled settings. This leads to valuable results, but it does not guarantee that any of them will be taken up and introduced on the market.

That is where large-scale pilot projects like Linear come in. They are far more complex to set up than an average lab test, but the unique mix of commercial parties and R&D players is exactly what is needed to give state-of-the-art research results that little extra boost that makes the difference between lingering forever on the shelf or moving on to become part of widely-used products.

Linear has been a major success in this respect. We are very proud of this project that turned out to be one of the largest, most advanced and most productive pilots in Europe. The sheer size of Linear, which included 240 actively-participating households over three years, is impressive for this kind of initiative. There have been other projects that included a higher number of participants, but never with the same level of involvement - and complexity - as what we achieved here. Moreover, Linear has not only given us a clearer understanding of how end users react to our technology, it has also led to new products and services that are on the market today. It has been the single best investment we could have made in shaping the energy landscape of the future.

Smart Appliances



Figure 19: prototype testing in EnergyVille Home Lab

Minimizing the impact on the comfort of residential users participating in demand response schemes was an important requirement in the Linear project. One of the means used to achieve this involved extensive use of automated 'smart' appliances. Such appliances are remotely controlled, which means that interaction with users can be limited while still respecting their comfort settings.

Smart appliances cover a wide range of technology, from electric domestic hot water buffers and buffered heat pumps to washing machines, dishwashers and other postponable white good appliances, including electric vehicles. Any smart appliance brought on to the market by any one of the major manufacturers and industries involved should allow for easy integration into any home energy management system. As a result, in Linear much effort was devoted to the matter of 'device abstraction', i.e. designing and using smart appliance interfaces that are as technology and vendor-independent as possible. For instance, the parameters used to control washing machines, dishwashers and tumble dryers were identical for all three types of devices and for both white good manufacturers participating in Linear.



Figure 20: electric vehicle charging in front of participant's house

Smart White Good Appliances



The Linear pilot used white good appliances from two manufacturers. Miele supplied smart-grid-ready washing machines, dishwashers and tumble dryers. These appliances communicated via PLC technology with a Miele Gateway¹ that in turn was connected to the Linear Home Gateway. BSH (Siemens) supplied Linear with 'traditional' non-remotely controllable washing machines and dishwashers. Remote control was through VITO white good smart grid controllers, designed and built for the Linear project and placed between the appliance and the wall plug. The controller technology can be applied to all postponable appliances that store program information regardless of power interruptions, and it requires no modifications to the controlled appliance².



While the communication technology used differed, the data supported by the interfaces was identical for all 5 models of white good appliances. When a user configured the appliance, he or she set a deadline as far as possible in the future. The appliance then sent the configuration time and start deadline, as well as an estimate of the power consumption based on the time, to the Linear demand response control server. At the best start time, the server sent the start signal to the appliance. If the Linear infrastructure failed to send the start signal before the start deadline, then local control of the appliances ensured that the program was started at the deadline, thereby safeguarding user comfort.



Figure 21: EnergyVille white good controller

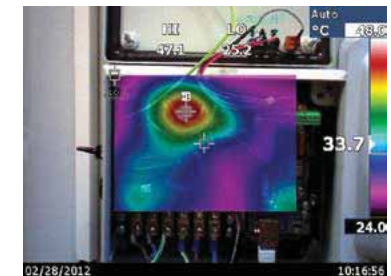

Figure 22: temperature scan of the energyville white good controller, ensuring that these controllers don't give cause to fire.

¹The Miele GW supports an XML over HTTP/Ethernet smart grid interface.

²The white good controller supports a JSON over http/Ethernet smart grid interface.

Smart Electric Domestic Hot Water Buffer

In Linear, the technology was developed to convert regular electric Domestic Hot Water (DHW) buffers to smart, remotely controllable ones¹. The buffers are equipped with a generic thermal buffer interface², which hides all buffer model specific details, such as dimensions, volume, etc. Instead, the interface expresses the available flexibility in terms of state of charge, power, the minimum state of charge that must be retained to cover the user's peak demands, etc.³

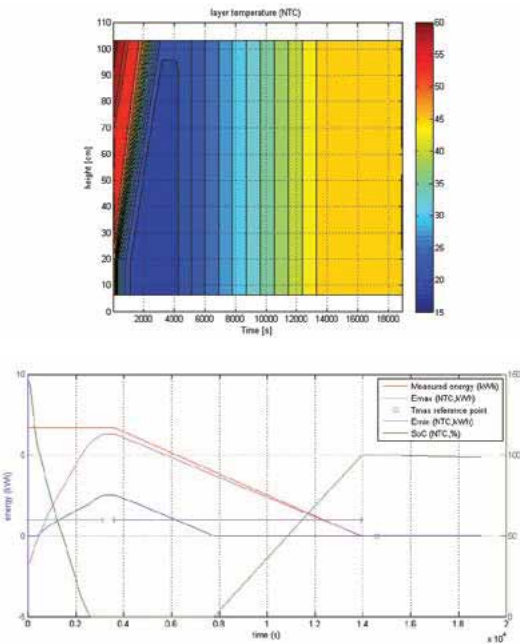

Coordinated Charging of Electric Vehicles

The charging of electric vehicles in the Linear pilot used the switching capabilities of the submetering plugs. When a user arrived home with his or her electric car, the car was plugged into the submetering plug in the garage. Then the user opened his/her Linear portal on a smart phone or tablet, and entered the departure time and the charging time as indicated on the vehicle's dashboard. Based on this data, the algorithms controlled the charging by switching the plug on and off.



Figure 23: the Linear electric vehicle user interface

¹ Vanthournout, K.; D'hulst, R.; Geysen, D.; Jacobs, G., "A Smart Domestic Hot Water Buffer," Smart Grid, IEEE Transactions on, vol.3, no.4, pp.2121,2127, Dec. 2012

² The smart DHW buffer support a JSON over http/Ethernet smart grid interface.

³ Domestic Hot Water Buffer Controller – patent pending, EP 11 168 672.1, PCT/EP2012/060527

ICT Architecture¹

A scalable, reliable and interoperable ICT architecture was designed, implemented and deployed for Linear (Figure 24). In each Linear household we installed a home gateway, i.e. the core local component of our system. This gateway communicated with the measurement devices and smart appliances and sent all collected data in real-time to the backend of the gateway provider. The data was then forwarded to the Linear pilot backend.

The backend integrated multiple gateway providers and supported multiple clusters per provider, with different business/control cases running for the various clusters. The pilot backend also received all control set points for the Balancing Responsible Party and Distribution System Operator control cases, for example wind imbalance set points, variable prices, real-time transformer measurements, etc. Based on this, and on the status data received from the households, the control logic generated appliance control signals which were sent via the pilot backend and gateway provider backend to the home gateways of the end users, and from there to the smart appliances.

Both scalability and interoperability proved to be crucial properties.

The centralized approach in Linear was the correct choice for a pilot since it facilitated data collection and analysis while providing the flexibility to easily set up and change experiments. However, the limits of the servers were pushed at all levels in terms of both number of transactions and amount of data. We managed, but a full scale roll-out should build on mature cloud/big data technology and/or distributed methodologies.

The attention given to and effort spent in Linear on proper interfacing and device abstraction proved to be a valuable investment and a key factor in the pilot's success. A wide array of technology from an equally vast range of sectors and industries comes together in residential demand response and only proper care for the interoperability can ensure that the puzzle is operational.

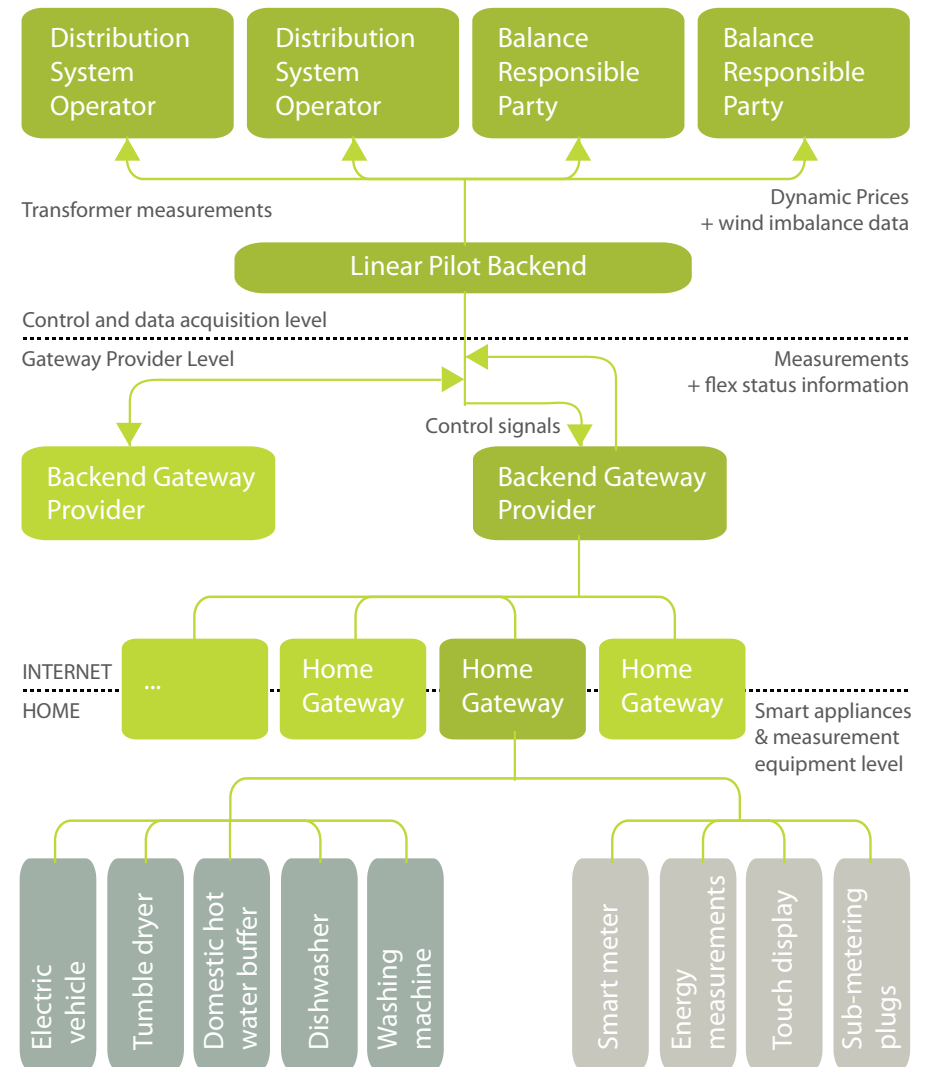

Figure 24: Linear's ICT architecture

¹Matthias Strobbe, Koen Vanthournout, Tom Verschueren, Wim Cardinaels and Chris Develder, "Deploying the ICT Architecture of a Residential Demand Response Pilot," in IM 2015 – ExpSession

Linear's backend was a complex ensemble of multiple servers (Figure 25), with the Live and Control Servers, managed by iMinds and Laborelec, being responsible for all tasks required for the day-to-day operations of the pilot. Linear used standard web service technology for communication with the backends of the different players. There was also a direct communication link via GPRS from the Live Server to the 5 transformers in the field. All data was replicated in real-time to the Data Server, where it was validated via scripts and where computationally-demanding experiment analyses were executed. Aggregated data was forwarded to the Development & Analysis Server for visualization via a dashboard tool that allowed for monitoring and follow-up of the ongoing experiments as well as fast detection of problems within the deployed installations. The same server also acted as a mirror for the Live Server so as to take over in case of serious malfunctions and to serve as test server for new features before deployment in the field.

All communication to the backend, and between the backend servers, was secured using state-of-the-art encryption and authentication technology. Access to the data was restricted on a need-to-know basis.

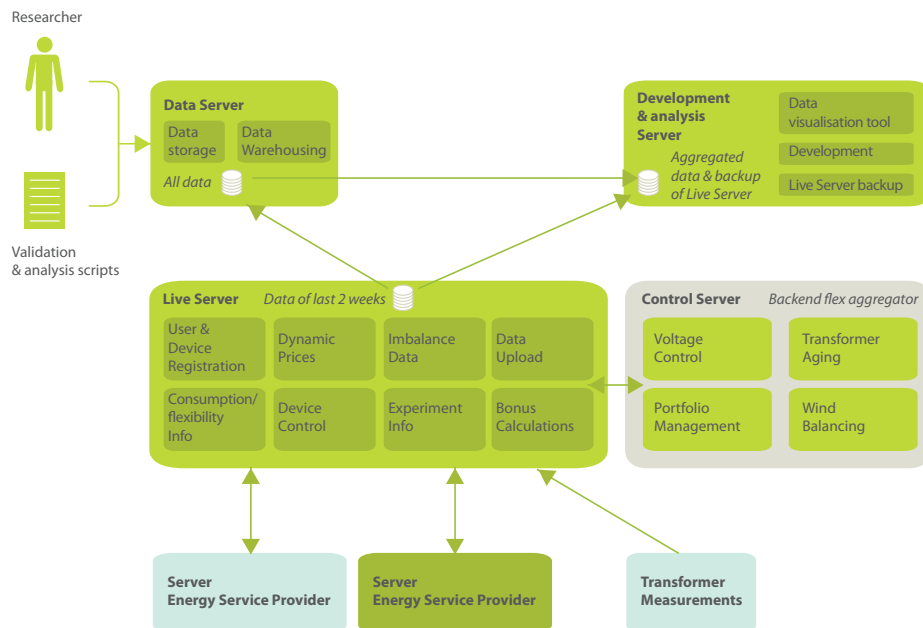

Figure 25: backend - a complex ensemble of multiple servers

INFRA X

Paul Coomans, Director Asset Management



INFRA X participated in Linear to investigate, under real-life conditions, to what extent residential flexibility could help in increasing the hosting capacity of renewables and defer congestion and voltage problems. Within Linear, we focused on two aspects that might become points of concern in the future electricity grid:

Grid constraints are local problems and need flexibility at the right place and in the right amount. These conditions are not always met. So the valorization of flexibility is more complex for a grid operator than for balancing service providers where the locational component of flexibility is not relevant.

Electric vehicles pose both a threat and an opportunity. With uncoordinated charging, they tend to significantly increase the load peak in distribution grids, while coordination mechanisms can shift charging to more favorable timeslots, e.g. during periods of low consumption (night) or high photovoltaic production (noon). **Heating applications, such as heat pumps and electric boilers, also show great potential for load flexibility** and local energy buffering, without loss of comfort for the end consumers.

To investigate these two issues of concern for the future, INFRA X installed a new transformer in Bret-Gelieren (Genk), equipped with the required measurements, including oil temperature, in order to obtain full integration into Linear and also made electric vehicles available for the participating families.

Based on the Linear experience, INFRA X drew three main conclusions:

1. Linear succeeded in making the various technology providers' components work smoothly together. This realization required major efforts from all partners involved and pinpointed **the value of standardization and interoperability.**
2. INFRA X advocates a **gradual roll-out of smart meters for specific consumer groups.** Based on the Linear experience, smart meters should preferably be placed in installations with local electricity production (photovoltaics) and/or with a certain flexibility potential (heat pumps, electric boilers, electric vehicles).
3. To obtain the engagement of the citizens, **appropriate tariffs** that impose the actual costs of reserved capacity and generated energy need to be developed. Regulation and legislation have to be adopted. Zones subject to limited regulations could be helpful.

We still need some more demonstration projects like Linear to gradually learn and optimize the energy system.

Measurements



Figure 26: Linear installation including an Eandis smart meter

Each Linear household was equipped with tools to measure total electrical energy consumption. For the geographically dispersed families that did not participate in the distribution system operator grid constraint management cases, this was measured using custom-installed measurement devices. For families in the Hombeek-Leest and Bret-Gelieren districts, total measurements were provided by two types of smart meters. Communication between the smart meter and the gateway was organized via the so-called P1 port¹, and included power and voltage measurements. If a photovoltaic installation was present, local solar production was measured separately.

Each household was also equipped with a set of sub-metering plugs. These plugs measured the individual energy consumption of the smart appliances and of the main electricity consumers in the household.



The Linear pilot deployed 5 transformers: 4 in the Hombeek-Leest district and one in Bret-Gelieren. These transformers were equipped for current, voltage, phase and temperature measurements, which were communicated in real time to the Linear backend and used for the transformer aging business case.

All Linear measurements were quarter-hour based.

Figure 27: the transformer in Bret-Gelieren was replaced by a new transformer with oil temperature measurement equipment.

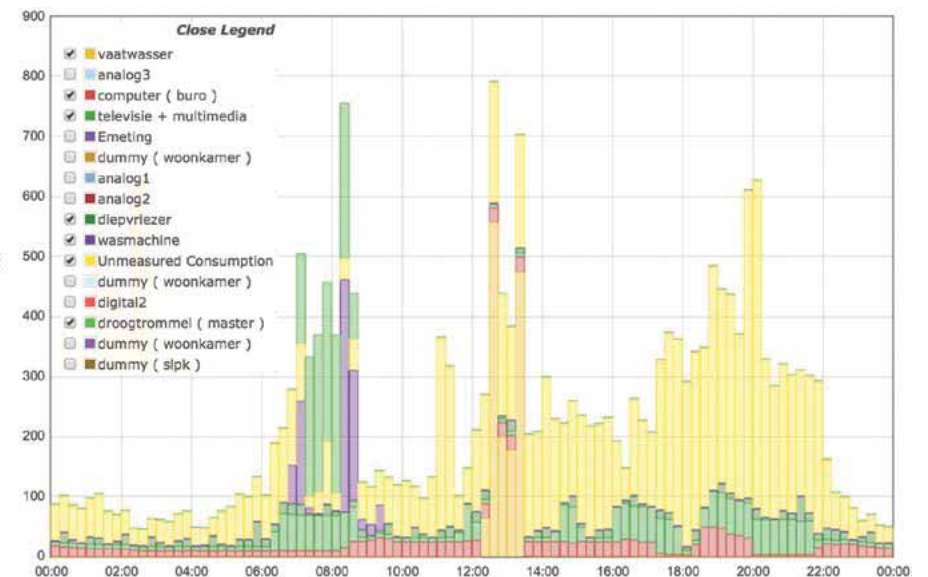

Figure 28: consumption of a single household during one day, as visualized by the Linear cockpit tool

¹The P1 protocols employed are DSMR 4.0, customized to include voltage measurements, and a proprietary XML over HTTP/Ethernet protocol.

Miele Belgium

Chris Vangrunderbeek, Marketing Director Miele Belux

Miele, which was established in 1899, is a family business for which sustainable trading has formed part of the corporate philosophy since the very beginning.

An important part of sustainability of course involves dealing with energy consumption issues and the related problems we face today and will face in the future.

In the (near) future, smart energy networks will make it possible to align energy demand and supply.

However, we can also contribute in our capacity as a manufacturer of domestic appliances. In this context, over the past few years we have seen the energy consumption of domestic appliances decrease spectacularly, among other things thanks to new developments in heat pump technology. Nevertheless, despite the fact that domestic appliances are becoming increasingly efficient they continue to account for a significant portion of household energy consumption. For this reason, smart domestic appliances are sure to contribute to the even more efficient use of available energy in the future.

That is why the Linear project was an excellent opportunity for Miele to take part in field research and discover the extent to which users of domestic appliances are willing to offer flexibility to the network without their comfort being affected. By indicating a period with an end time by which a particular program has to be completed, the “smart current network” will be able to determine when that program is started.

The decision to make our smart domestic appliances part of the project was taken quickly, certainly in view of this technology (Smart Grid) already being a standard feature of certain Miele domestic appliances, namely automatic washing machines, automatic clothes dryers and dishwashers. As a manufacturer, we also believed that users would be most willing to offer flexibility through these appliances.

Together with Miele's head office in Gutersloh, we will undoubtedly extract new and interesting insights from the Linear results. The significance of smart domestic appliances will only increase as the role played by smart meters and smart networks expands further. Participation in Linear strengthened our conviction that we are ready for this new challenge and that Miele's smart domestic appliances will contribute to more efficient energy consumption going forward.



fifthplay

Kris van Daele, Managing Director

The world of energy is changing and is set to change a lot more in the near future. At fifthplay we are aware of these challenges and are working hard to develop appropriate solutions. This is why we played an active role in the Linear project, the goal not only being to study and learn, but also create.

An energy landscape with multiple renewable energy sources is good for the environment, but it also challenges people to use their home appliances differently. For example, we will have to learn to make maximum use of electricity when it is available from solar or wind sources. The technology developed by fifthplay makes it possible to communicate with home appliances, boilers, heat pumps, electric vehicles and other devices, meaning that they become ‘connected’. By connecting devices to the fifthplay cloud platform, we can use additional information such as real-time energy prices, weather forecasts, etc. to make these devices intelligent and automate them. People will not have to do the calculations and control operations on their own, and instead connected devices will operate in the most efficient manner and use renewable energy when it is available.

Our role in Linear proved that the technology is ready, and the families that participated in the project showed that people are willing to use it. Now, it is up to policymakers to lay out a regulatory framework that enables energy companies, service providers and manufacturers to bring these solutions to the market.

Linear was not only a project where we learned a lot, but also a delightful opportunity to work with several professional partners, leading to new partnerships and ideas. We would also like to thank everyone who participated in Linear in one way or another for the constructive teamwork; this project is definitely a new step towards a more sustainable future.



In-house Equipment

To the greatest extent possible, Linear decided to make use of its partners' existing products for integration into the Linear system. The fifthplay Home Gateway was the central building block between the Linear servers and the devices in the house. For data communication, the Linear system used the participants' existing high-speed internet connection. Together with the gateway, energy meters with pulse output were installed to measure energy from photovoltaic panels, total consumption and heat pumps. Via sub-metering plugs, we measured the energy consumption of the household appliances.

'Some families were so excited about the possibilities of the Home Energy Management System that they started moving plugs to different locations in order to trace standby losses, not being aware that they were messing up the network to the extent that the fridge plug started showing the behavior of a television in our databases.'

Gert, Linear support team

Setting up stable wireless communication such as Wi-Fi and ZigBee between the different floors is no easy task. For this reason Linear installed on average 11 ZigBee plugs in each home, half of them serving exclusively to bridge communication signals. Linear preferred Ethernet over PLC to Wi-Fi for connecting the different modules in the house with the fifthplay Home Gateway. This choice quite often caused conflicts with existing applications such as the home network and digital television. As a result, our technicians repeatedly needed to reconfigure and test the complete in-house communication setup.

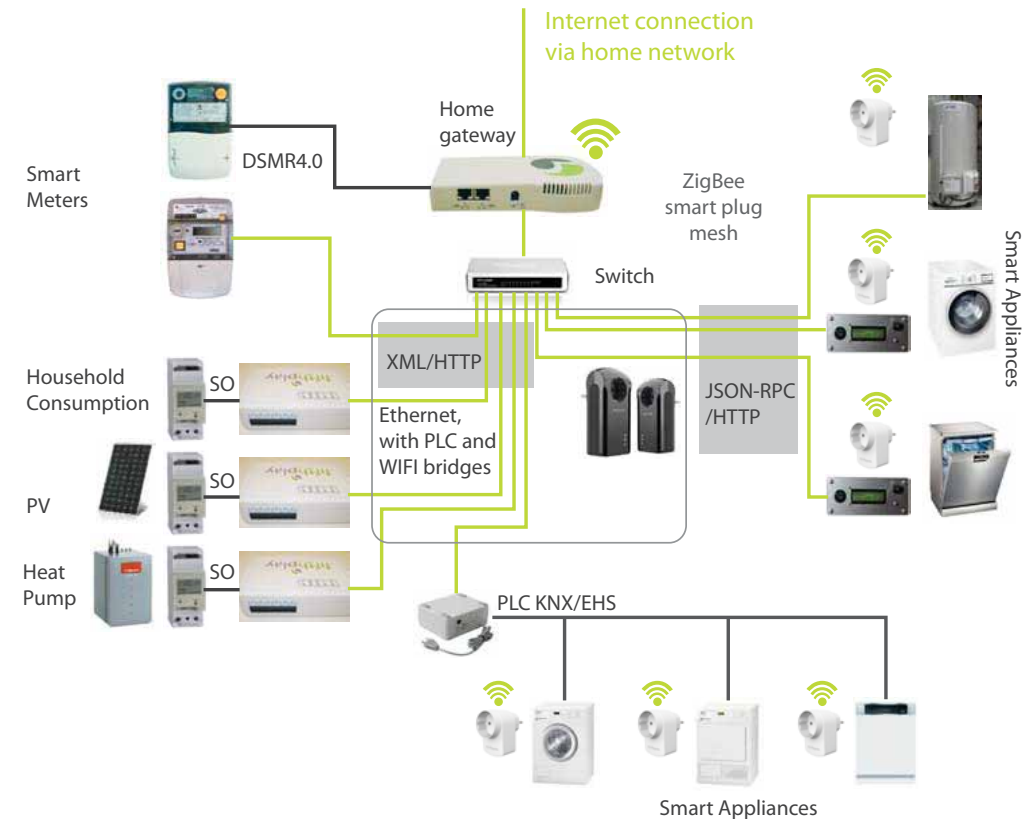

Figure 29: Linear in-house installation

In-house communications were one of the major sources of technical malfunctions (10.1. Participant's concerns). The Linear installations are retrofits, so wired solutions were not an option for all but a few connections. Residential demand response components are typically located in such outlying corners as the cellar, attic, garage, etc. The attenuation caused by this is aggravated for PLC when there are multiple parallel PLC systems; wireless is hampered by the abundant use of stone and iron in Flemish dwellings. Wireless access points next to or behind the appliance's metal casing are also a noted attenuating factor.

The result is that we did not find a plug&play in-house communication solution that works for the majority of the households. This is a topic that must be addressed before a full scale roll-out. However, Linear did speed up and advance the partners' product development since the two communication components that caused most of the field interventions were phased out and replaced by better technology while the project was still running.

Proximus

Wim De Meyer, Head of Group Innovation at Group Strategy & Transformation



Proximus is committed to providing a superior user experience by building an integrated and evolving portfolio of smart home and smart organization products and services, as well as to constantly keeping people in touch with the world so they can live better and work smarter.

Our ambition is to deliver performance, peace of mind, reliability and value while helping to deal with societal changes and challenges. We invest in major areas of development such as security & privacy, comfort & energy, care & wellbeing, cloud, machine-to-machine, collaboration and mobility, just to name a few.

Proximus believes that achieving these objectives is only possible by bringing together an ecosystem of partners and competences from multiple horizons, all working to create a better future and shared value for our society.





To that end, Proximus is always looking ahead to fulfill customers' needs over 5 to 10 years. This means that Proximus is investing today in smarter fixed and mobile networks, as well as enabling platforms for our partners, while always paying special attention to delivering high-quality solutions and services.

We also devote extra attention to setting an example and play a pioneering role to guarantee data confidentiality and privacy protection, for instance by reinforcing Proximus' commitment towards cyber security in all its aspects, and by sharing knowledge with the authorities, customers and partners.

For all these reasons - and also many others - Proximus wishes to thank Linear for giving us the opportunity to co-create innovative solutions and make a positive contribution to economic, social and environmental progress.

Test Families

In the first stages of Linear, we tested the technology in our Home Labs. In the meantime, Linear had started recruiting 240 families that were prepared to integrate this experimental technology into their homes and use it in their daily lives.

	Smart Meter	No Smart Meter
Smart Appliances	85 families  Interface: Smart Start Business Cases tested: <ul style="list-style-type: none">• Portfolio Management• Wind Balancing• Transformer Aging• Line Voltage Control	101 families  Interface: Smart Start Business Cases tested: <ul style="list-style-type: none">• Portfolio Management• Wind Balancing
No Smart Appliances	21 families  Interface: Time of Use Tariff Business Case tested: <ul style="list-style-type: none">• Portfolio Management	33 families  Interface: Time of Use Tariff Business Case tested: <ul style="list-style-type: none">• Portfolio Management

Within this field trial Linear created different groups of test families, to be distinguished based on whether or not they had a smart meter and/or smart appliances installed. All families with a smart meter were concentrated around selected transformers in districts located in Hombeek and Leest (Eandis) and Bret-Gelieren (INFRAX) so that we could investigate the impact on the local grids.

Recruitment

Linear's recruitment process yielded a total of 240 families active in the field test and spread over Flanders, with two concentrations in Hombeek-Leest and Bret-Gelieren. Recruitment was organized in three phases:

Phase 1: Friendly Users

In order to test the Linear systems and procedures, Linear decided to start with 'Friendly Users'. We recruited 30 such users, all employees of our partners. As it turns out this was a useful test because quite a few systems did not perform as expected, and a lot of effort was spent optimizing the installation procedures. Based on this experience, a support team was established prior to the start of installation work for phase 2.

Phase 2: Families in Flanders

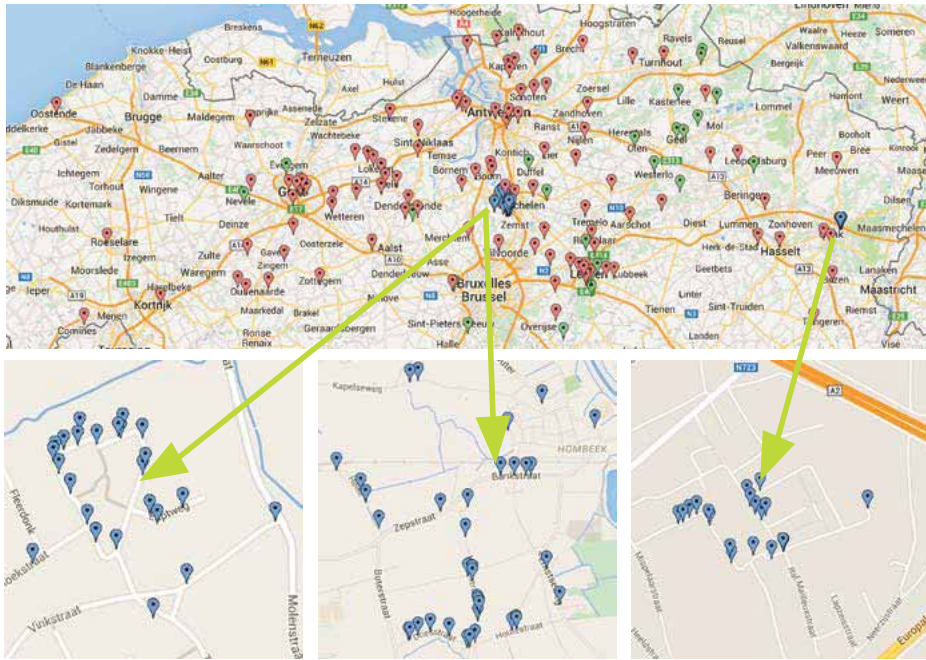

Figure 30: households participating in the Linear field test

For phase 2, Linear had the luxury of being able to select 100 Flemish families out of 1500 volunteer participants.

For practical reasons, Linear only recruited families with the following characteristics:

- Living in a house, not an apartment (accessibility of utilities)
- Owner of the house (contract, liability)
- Broadband internet available (Linear Home Energy Management System)
- Willing to invest in smart appliances

As a result of this selection, most participants had completed higher education and had a matching higher salary. The majority of persons were between the ages of 30 and 50 and had children.

Phase 3: Families in a Local Grid

In order to be able to test the impact of Linear on the local grid, a third recruitment phase was scheduled. This last one was much trickier because we needed to recruit one family out of 3 in a single street for the effect to be measurable. The initial response to the recruitment efforts demonstrated that the Linear conditions were not perceived as attractive enough for families to replace their existing appliances.

Recruitment was more successful after dropping the purchase obligation and deciding to offer appliances free of charge with an option to buy at the end of the project, especially in Bret-Gelieren where participants could also try an electric car during 10 weeks for free. Participants with older appliances were now willing to consider an early replacement. At the end of Linear, 99% of participants with a purchase option decided to buy the appliances used during the test.

'Ten years ago I bought Miele appliances with an A-class energy label with the intention of using them for 20 years. What is sustainable about replacing them now?'

Response of a candidate during a phone call evaluating the poor response in the first stage of Phase-3 recruitment

EANDIS

Donald Vanbeveren, Director of Regularization and Strategy



Eandis took part in Linear primarily to gain an insight into the possibilities offered by smart demand-side management for network management. The key question was: can this technology enable us to inject **more locally-generated power into the electricity network?**

For this to be possible, smart demand-side management should be able to assist families in **adapting their electricity consumption based on the available solar and wind energy.** We would then be able to reduce both the typical consumption peaks in the evenings and any injection peaks from solar panels in the afternoons. Worth noting here is the recent debate

on energy shortages, which has added a new dimension to the topic. The research results yielded a number of significant insights in this context as well.

It was essential for Eandis that Linear went beyond a conceptual study, and that was indeed the case as it involved a real, **practical test for 75 families in Leest and Hombeek whose homes were fitted with a smart electricity meter.** Some 54 households also participated by using smart household appliances. As a result of their participation we were able to thoroughly assess not only their experiences as users, but also the technical solutions.

These three conclusions reached by Linear are important to Eandis:

- To a certain extent, demand-side management using smart appliances can help to reduce some consumption and injection peaks on the electricity network. From the network manager's perspective, washing machines, tumble dryers and dishwashers are less suitable than electric boilers and vehicles, which can be put to use very flexibly. This approach can also have a positive effect on the voltage quality of local electricity networks with substantial local generation.
- As for the smart meters in Leest and Hombeek, they offered sizeable added value. They provided detailed information on energy consumption, thereby enabling thorough investigations and data analyses. Moreover, their potential added value in terms of energy savings was reconfirmed: some 40% of participants who regularly checked their smart meters noticed that this helped them consume less energy.
- Generally speaking, participants from Leest and Hombeek were extremely positive as regards the use of smart appliances. Most respondents experienced no reduction in comfort during the practical field test and lost no sleep because of privacy issues. On the other hand, certain consumer habits are deeply ingrained, such as the current day and night rates, and considerable effort will be required to change them.

Eandis is pleased with the Linear's research results. In particular, they revealed possibilities for a number of innovative techniques for demand-side management in various areas. However, in order to apply them on a large scale a number of major technical, economic and legislative obstacles still need to be overcome.

Installation

For the installation of the Linear system in the participants' homes, we started with the smart household appliances, followed by the system itself. Next, we installed a Home Energy Management System to measure overall consumption and generation, as well as consumption of individual appliances, on a 15 minute level. The purpose for this was to set the reference. In the third step, the Linear control system was activated and the families started living in a smart house.

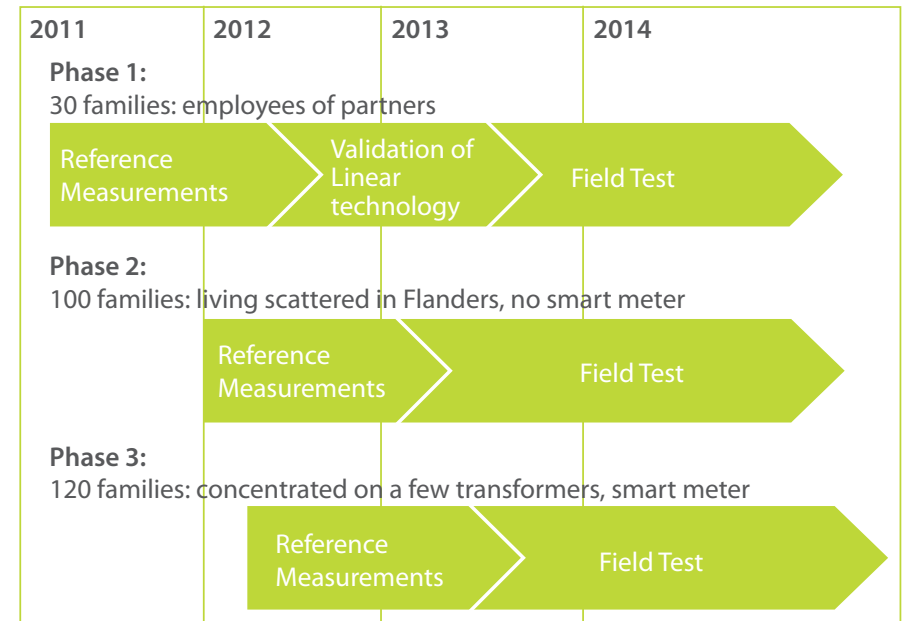

Figure 31: time schedule of the Linear field test

Prior to activation of the Linear system, a technician went on-site to execute the required updates, install missing communication devices and test all systems. Next, our support team traced all the device IDs and configured all related systems on the Linear servers. The purpose here was to establish the communication chain over the different data servers before we activated a real-time interaction between the devices and business cases. Finally, the family received a mailing, containing advice on how to interact with the Linear system and asking for feedback to facilitate the support team in double-checking the functioning of the system.

Installation took an average of four hours for the houses without a smart meter. For the houses equipped with a smart meter, the technician only needed to install the Home Energy Management System and plug a cable into the P1 port of the smart meter, reducing the installation time to two hours. More complex situations without a smart meter and including multiple photovoltaic systems or heat pumps often pushed the installation time up to around eight hours.

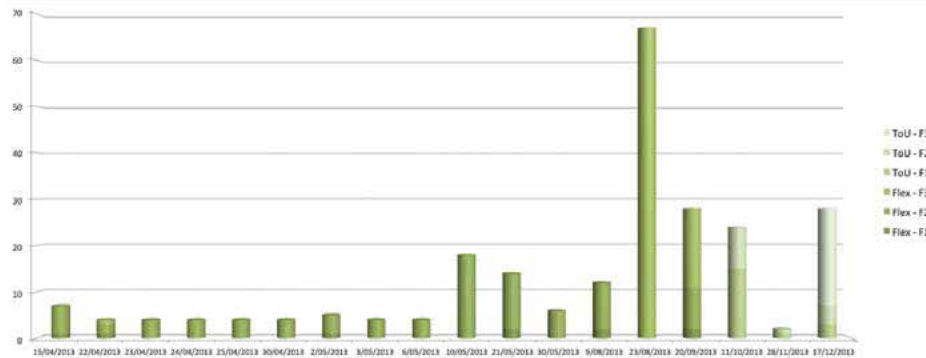

Figure 32: we activated approximately four families a week starting in april 2013. This sequence was stopped in June because of an increase in systematic communication failures under certain circumstances. After thorough analyses and additional testing, the remaining smart appliances were activated in august 2013.

Remuneration Models

Two remuneration models were tested in the Linear pilot project. The 185 Linear families with smart appliances received a capacity fee for the flexibility they offered. The 55 families without smart appliances participated in a dynamic tariff remuneration scheme. These remunerations did not replace the original energy contracts of the participants; instead all families still paid their own energy bills, and the remunerations served as a bonus or cost reduction.

Linear also covered the extra costs brought on by the pilot project through a number of additional financial compensations:

- Participation in the Linear pilot project included the installation of an extensive array of equipment, including prototypes not optimized for energy consumption. Linear provided an annual compensation of 30 euros.
- A large part of the Belgian households subscribed to a dual tariff system, with a lower tariff being applied to nights and weekends. Some of the Linear business cases required a shift from a high to low tariff. Linear returned the difference for any decreased share of the low tariff in the total consumption before and during the pilot project.

Capacity Fee

The objective of the flexibility remuneration for those participants with smart appliances in their homes was not to provide a realistic economic payment. Rather, the purpose was to encourage the participants to provide as much flexibility to the Linear system as possible, as their habits permitted and within their comfort boundaries. Linear could then quantify the potential of residential automated demand response. In support of this main objective, the remuneration fee had to be simple and intuitively understandable for the participants. A capacity fee complied with these requirements. Note that with a capacity fee, the users needed not be aware of which type of control was active.

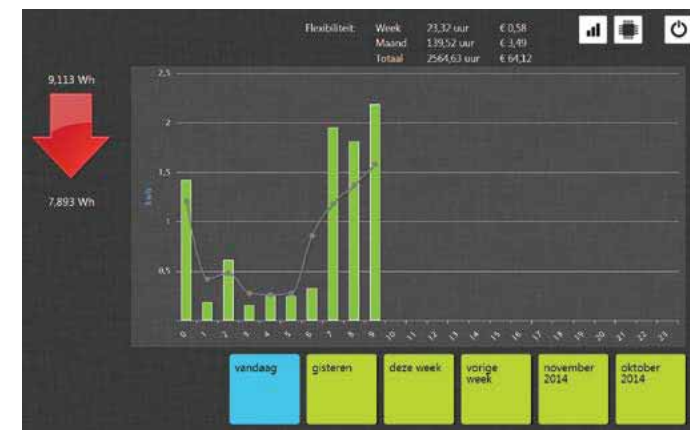

Figure 33: the user interface depicting the total flexibility capacity accumulated

Conclusions on the Capacity Fee

The Linear pilot project demonstrated that a capacity fee system works well from a user perspective. Once users have been convinced to start using the system, they keep doing so without significant response fatigue (p.86 User Fatigue). No complaints beyond technical malfunctions were received. Users did let us know that they would like to be able to see what their flexibility is used for.

The Linear capacity fee applied only to those appliances that require interaction from the user, i.e. the major appliances and electrical vehicles. The smart domestic hot water buffers were not included. As a simple metric for “amount of flexibility”, the hours of delay configured were used, i.e. the numbers of hours between configuration of the device and start or departure deadline. The Linear fee was set at 1 euro per 40 hours of flexibility.

Dynamic Tariffs

The Linear families without smart appliances participated solely in the portfolio management business case. They were presented with dynamic prices and were requested to manually shift their consumption from the more expensive periods to when prices were lower. For this purpose, they had access on their Linear portal to a webpage that displayed today's and tomorrow's prices.

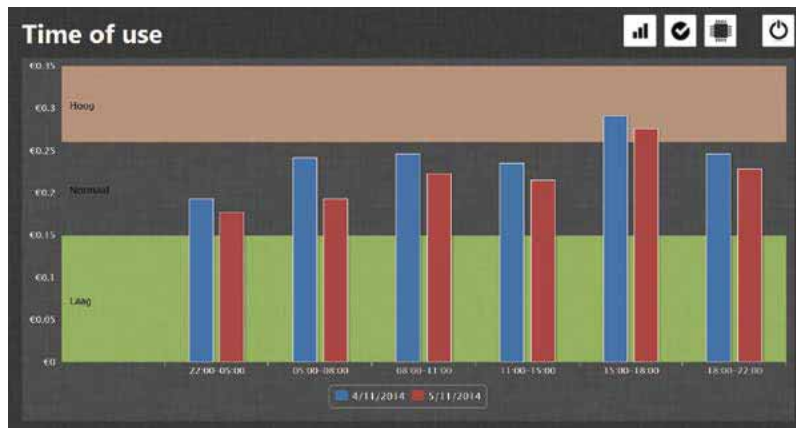

Figure 34: the user interface displaying today's and tomorrow's dynamic tariffs.

The remuneration was calculated based on the energy participant's shift relative to the reference consumption. The reference consumption was calculated per day and per user, based on the measurements collected during the reference period. It was composed of a reference energy value per tariff block, calculated using a weighted average of nearby days, with a distinction between week and weekend days.

The financial bonus was calculated by applying the dynamic tariffs on the shifts compared to the reference of the shares of the consumption per tariff block in the daily consumption. This implied that shifts from expensive to cheaper periods increased the participant's total bonus; conversely, a shift toward more expensive periods decreased the bonus. All dynamic tariff participants started the pilot project with a bonus of 100 euros.

Conclusions on the Dynamic Tariffs

Users found the dynamic prices and responding to them too invasive, too much effort, and too complex, resulting in response fatigue and only very limited behavioral changes. The reference curve mechanism also did not perform as expected. Factors such as changing family composition, electrical equipment install base, etc. reduced the correctness. Together with the limited availability of reference measurement data for participants recruited into the project later, the reference curves proved a rough approximation at best.

Families participating in the manual Time of Use tariff scheme were activated at the end of 2013, after having adapted the algorithm. The results of this tariff scheme with the original algorithm tested with a few Friendly Users showed that the Linear system was rewarding energy savings more than the intended shift in time of energy consumption.

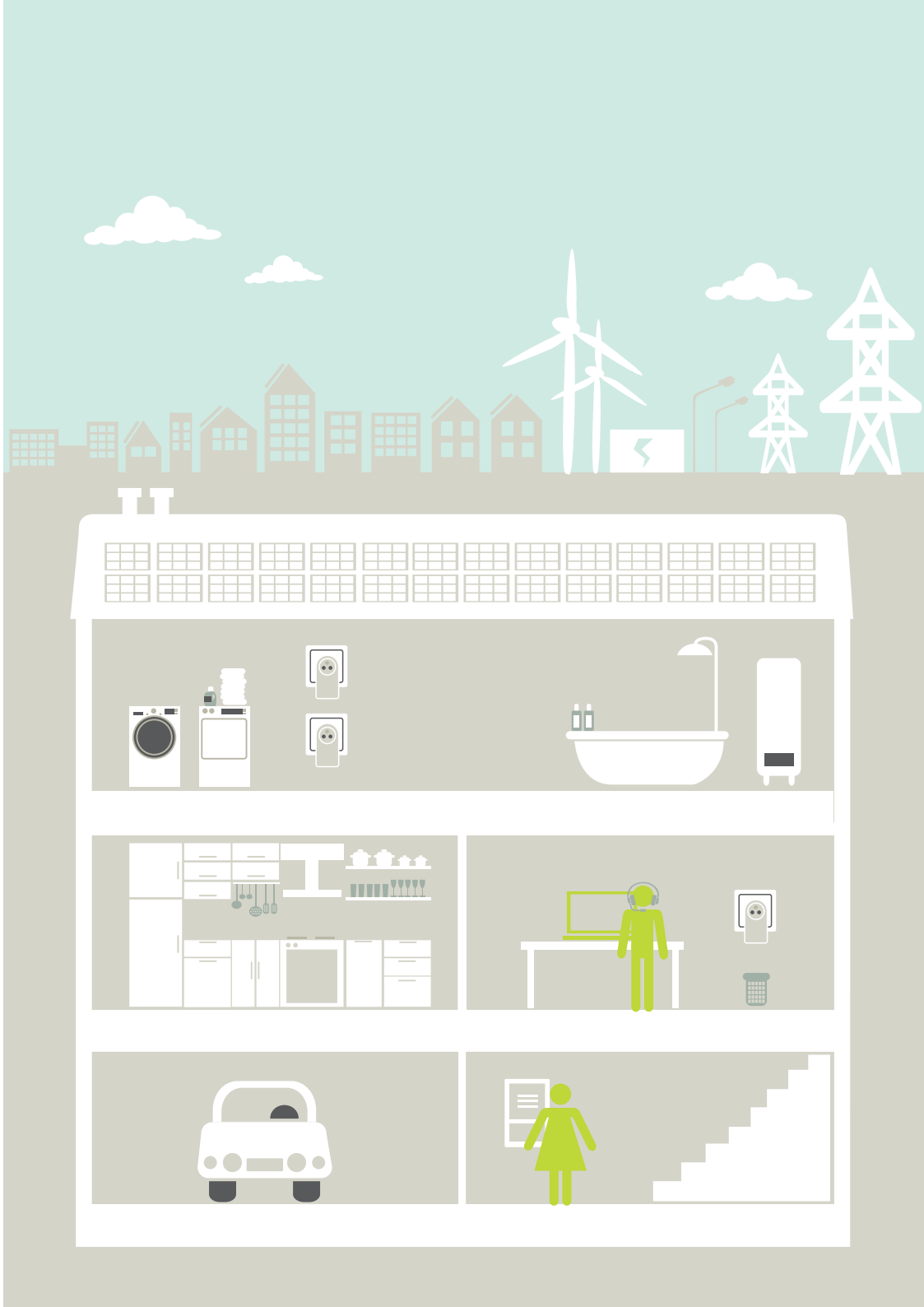

Families: Lessons Learned

Families: Lessons Learned

Participant's Concerns

During the entire Linear field test the support team was the main point of contact between the families and Linear. They were in the lead for recruitment, installation, follow-up and interventions.

For recruitment, communication was primarily via newsletters and web forms so as to structure all information. Individual questions were dealt with via a ticketing system. In total we processed about 2,500 tickets in 3 years' time for the 240 families involved.

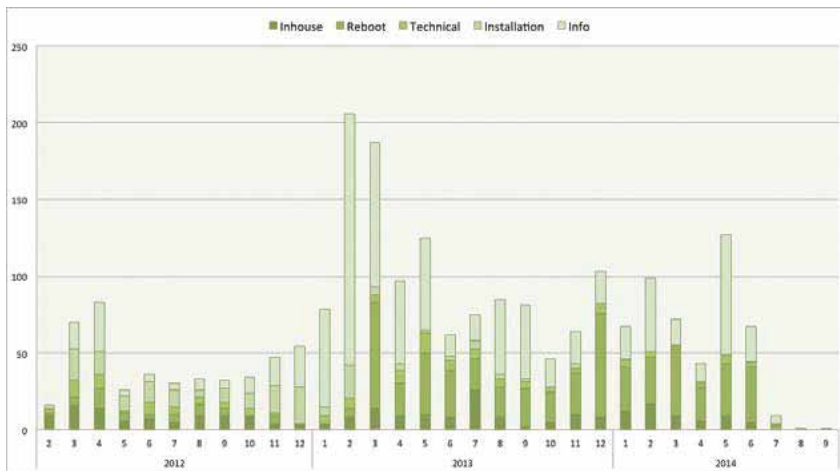

Figure 35: evolution and type of participant issues over time. Peaks emphasize a change in activity: at the beginning of 2012 the deployment of the energy measurement system was a source of questions, while at the beginning of 2013 the focus moved towards activation.

- Of the ticketed issues, the group with the biggest impact on the field test consisted of data communication problems affecting our devices inside the homes. We can distinguish problems in setting up stable in-house communications on the one hand and a loss of communication on the other. These issues were often solved by manually rebooting the devices in question.
- A second group concerned the installation of the Linear system and covered specific practical situations and technical issues, such as defects and component configuration.
- In a third group we categorized concerns about the exchange of information. Here the support team would share or mail guidelines and personalized advice on how to improve the bonus, manuals on how to use the Linear system, requests for specific feedback via questionnaires, etc. This group also included activation of the individual users.

“We were challenged by a lot of communication problems in the Linear field test. And sometimes, on rare occasions, they turned out to be caused by user behavior. For example, we were investigating why a boiler was systematically going on/off line. In the end it turned out that the family had installed a time relay to ensure that their boiler was only active on the off-peak tariff.”
Jan, Linear support team

Flexibility offered by the participants

Washing Machines, Dishwashers, Tumble Dryers

In total, the Linear families offered 200,000 hours of flexibility with their smart appliances. One family even succeeded in offering 9,800 hours with 3 appliances over 18 months!

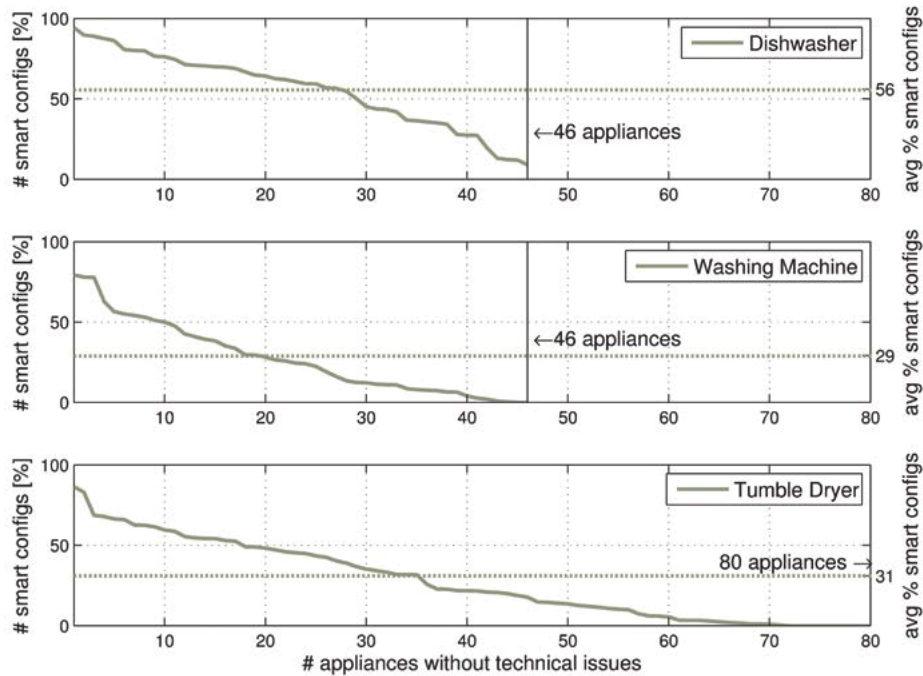

Figure 36: measured percentage of smart configurations of all wet appliances, together with the average number of smart configurations of the users giving flexibility.

In the Linear pilot we noticed that users did not configure their (white good) appliances flexibly every time they were used. However, the number of users who never configured their appliances flexibly was very limited. On average, dishwashers were configured with more flexibility than either washing machines or tumble dryers.

Most flexible configurations of wet appliances take place during the evening, and in particular dishwashers are configured as flexible at that time, thereby providing flexibility during the night. There is a slightly higher chance of a flexible configuration during the day on the weekend.

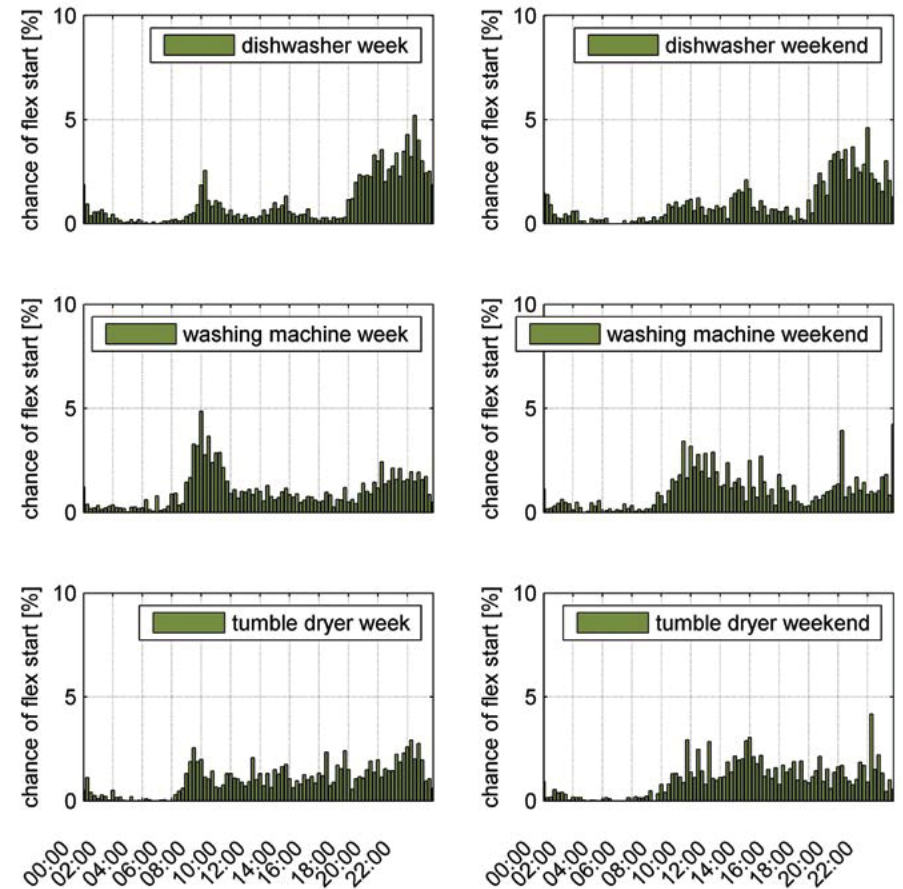

Figure 37: variation of likelihood of flexible configuration during an average weekday and weekend day, for each wet appliance.

The bulk of flexible configurations give a flexibility window of between 1 to 13 hours. On average, the same flexibility is given to all wet appliances.

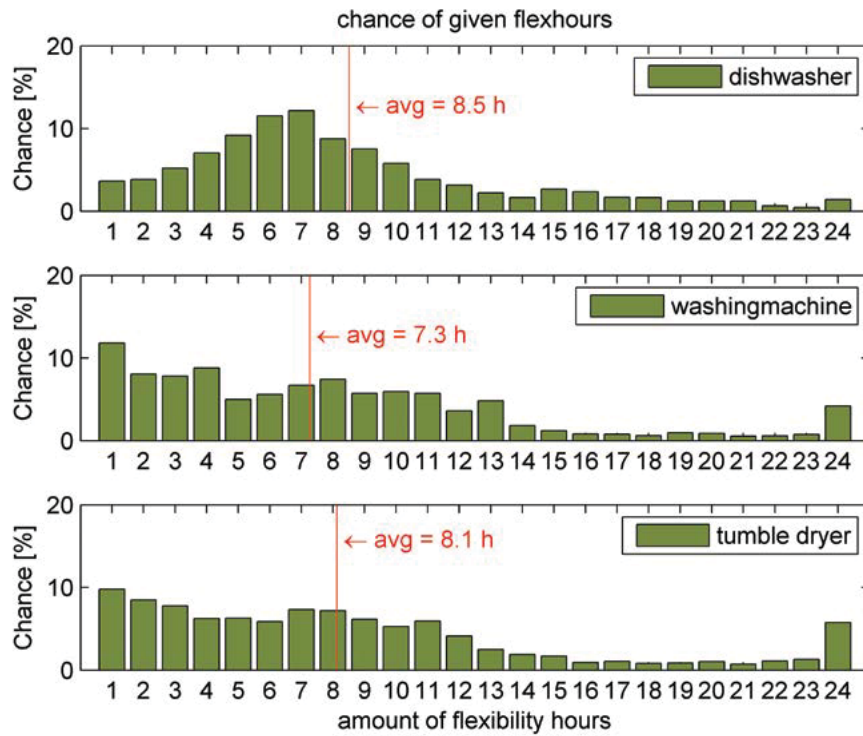
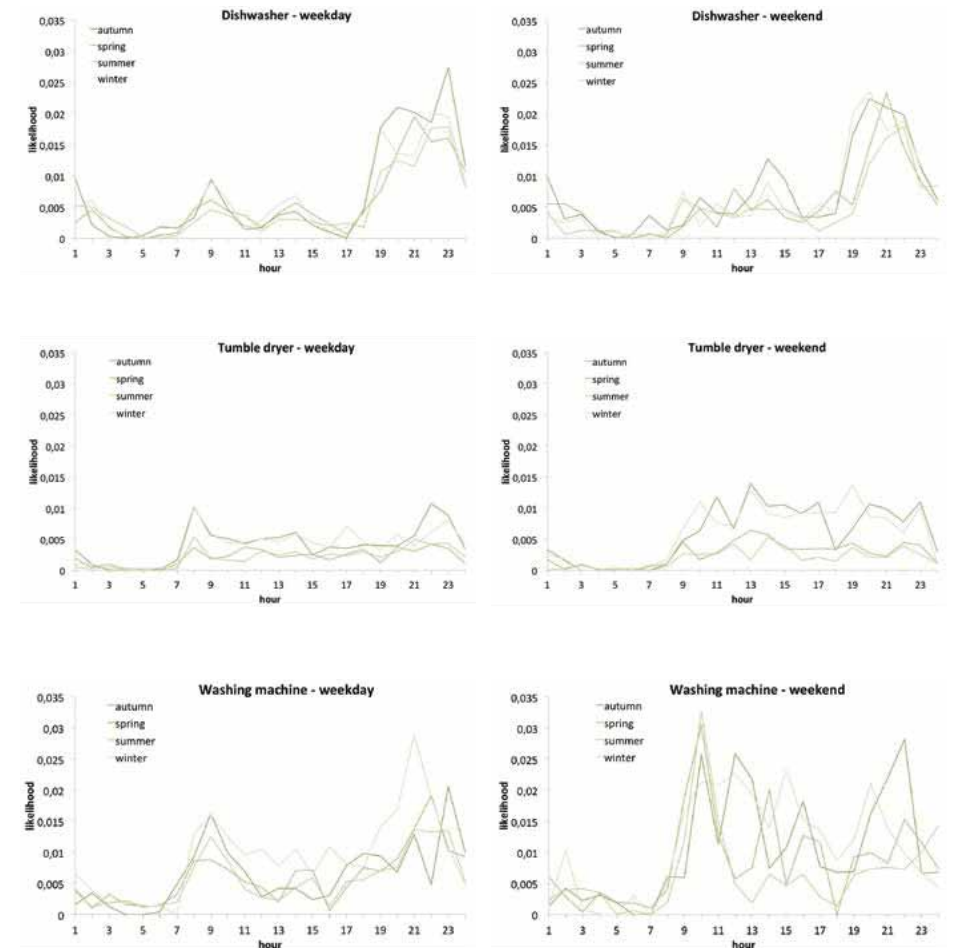

Figure 38: likelihood of amount of flexibility hours given per flexible configuration per wet appliance. The average number of flexibility hours per appliance is also indicated.

Seasonal Influences

We checked the impact of the different seasons on the number of flexible starts for dishwashers, washing machines and tumble dryers. Only limited seasonal effects were noticed for dishwashers, but tumble dryers, on the other hand, were more often flexibly started during winter, i.e. twice as much as in the summer. The seasonal effect for washing machines was more prominent than for dishwashers, but less pronounced than for tumble dryers. Once again, here the highest number of flexible starts was found in winter and the lowest during the summer.



White Good Appliance Flexibility Extrapolated to Belgium

Extrapolating the flexibility potential of white good appliances to the Belgian population of 4.6 million households (2009 data) leads to a maximum of 2 GW that can be called on additionally during the day (for 30 minutes), and a maximum of 280 MW that can be delayed (for 15 minutes). To calculate this flexibility potential, we took into account all pilot users that configured their smart appliance as flexible at least once during the pilot test.

Flexibility potential has been found to be highly asymmetrical: at any given moment during the day, more devices can potentially be switched on than maximally delayed. The flexibility potential is found to be higher during a weekend day than during a weekday. The highest potential is found during evening and nighttime hours, especially for weekend days.

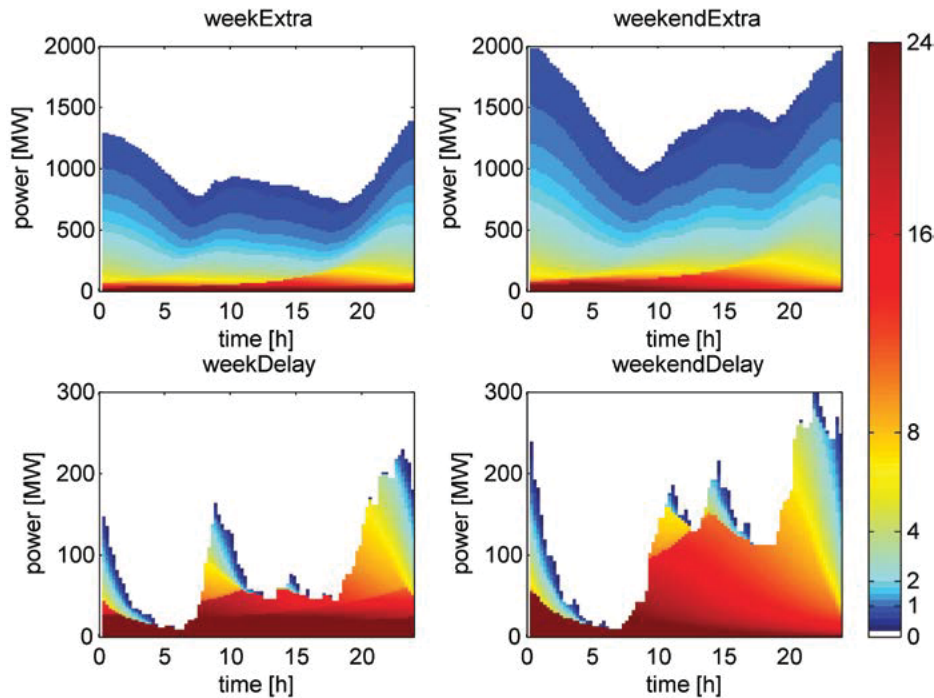

Figure 39: flexibility potential of all wet appliances (dishwasher, tumble dryer, washing machine) combined for all households in Belgium.

The color scale indicates the duration (hours) that the power shift can be continued

Electric Hot Water Buffers

In total, 15 domestic electric hot water buffers (DWH) were rolled out in the Linear pilot, and 10 of the DWH measured were reliable enough to be considered for further flexibility analysis.

Flexibility potential is defined here as **the maximum time a certain power draw can be delayed or additionally called upon at a certain moment during the day**. An important aspect of representing the flexibility potential as done here is that it represents a **snapshot** in time: it shows the potential of the appliance cluster before any action calling on flexibility has been taken. It gives the maximum potential that is theoretically possible, whereas the actual potential changes each time flexibility was used by the control system.

The flexibility potential of the hot water buffers for an average day shows that, during such an average day, a maximum of 24 kW can be called on additionally for at least 15 minutes (during the night) as well as a few hours (during daytime). Only 3 kW can be delayed maximally, while generally power can be delayed for more than 10 hours during the day. No difference between weekdays and weekends was noticed.

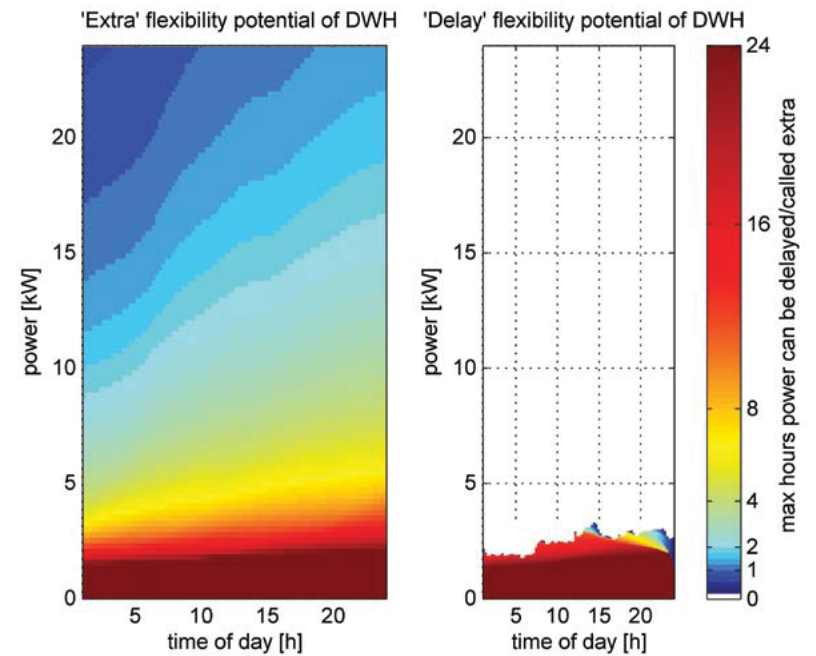

Figure 40: flexibility potential of the 10 domestic water heaters analyzed for the pilot test.

Electric Vehicles

Most flexible configurations for electric vehicles were initiated during the evening, providing flexibility during the night. The peak for flexible configurations on weekends was a bit earlier than during the week.

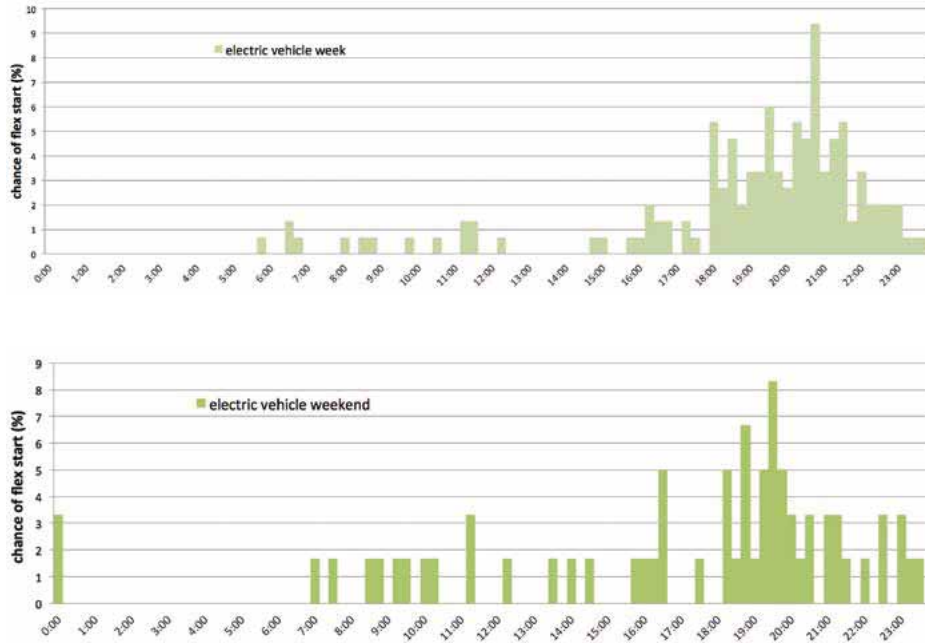

Figure 41: variation in probability of flexible configuration during an average weekday and weekend day for an electric vehicle.

The majority of flexible configurations yielded flexibility windows of between 1 to 12 hours, with an average of 5.6 hours.

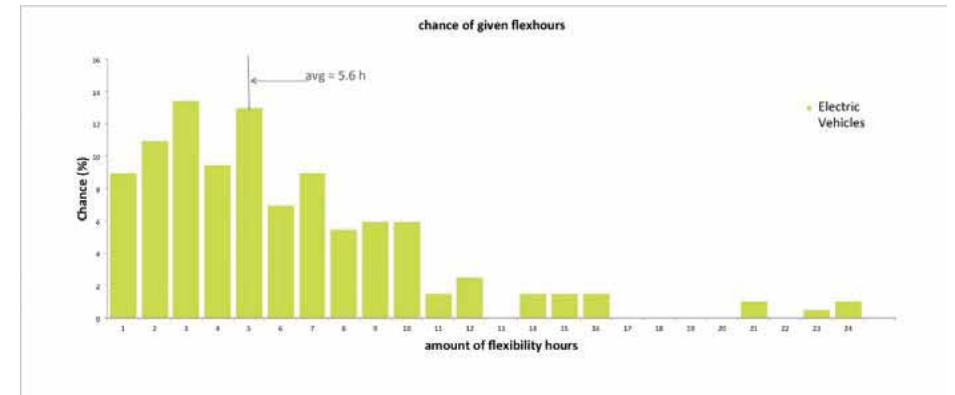

Figure 42: probability of number of flexibility hours given per flexible configuration for an electric vehicle. Average number of flexibility hours is also indicated.

Flexibility potential is defined for these purposes as the maximum time a certain power draw can be delayed or called additionally at a certain moment during the day, analogously to the electric hot water buffers (p.81 Electric hot water buffers).

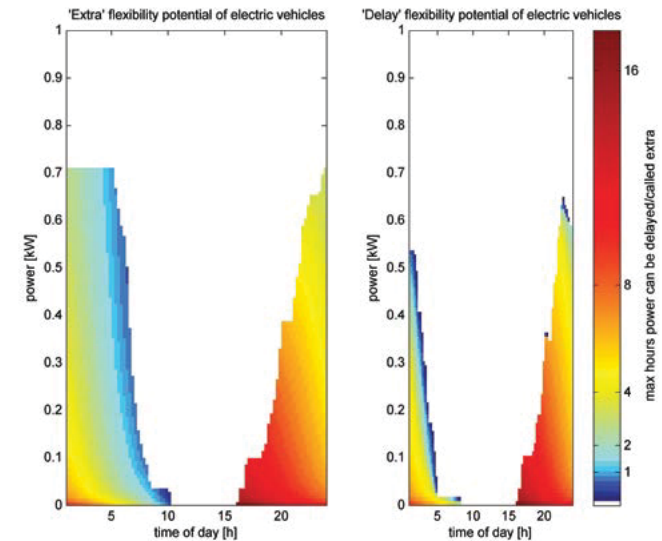

Figure 43: flexibility potential of the 32 electric vehicles analyzed in the pilot test based on the flexibility entered by drivers.

If we only look at the flexibility entered by drivers using the Linear web interface, the flexibility potential of the electric vehicles showed that on an average day a maximum of 0.7 kW could be called additionally for at least 1 hour during the night. During the day, no flexibility was given. Only 0.65 kW could be delayed maximally during the evening, with no delay possible during the day. These numbers are very low because **drivers only very rarely provided flexibility**. We asked them to enter their flexibility via a web interface (estimated departure time, hours needed to charge), but the burden was probably excessive, thereby leading to very low response rates.

If we do not look at the flexibility that was entered via the web interface but instead look at when the vehicle was plugged in, and when it was unplugged, we can calculate the maximum potential for flexibility. This data showed that almost 28 kW could be called additionally for at least 2 hours during the night, and also that during the day an extra 10 kW could be called up. Some 18 kW could be delayed, mostly during the evening, and again during the day about 2.5 kW could be delayed for several hours.

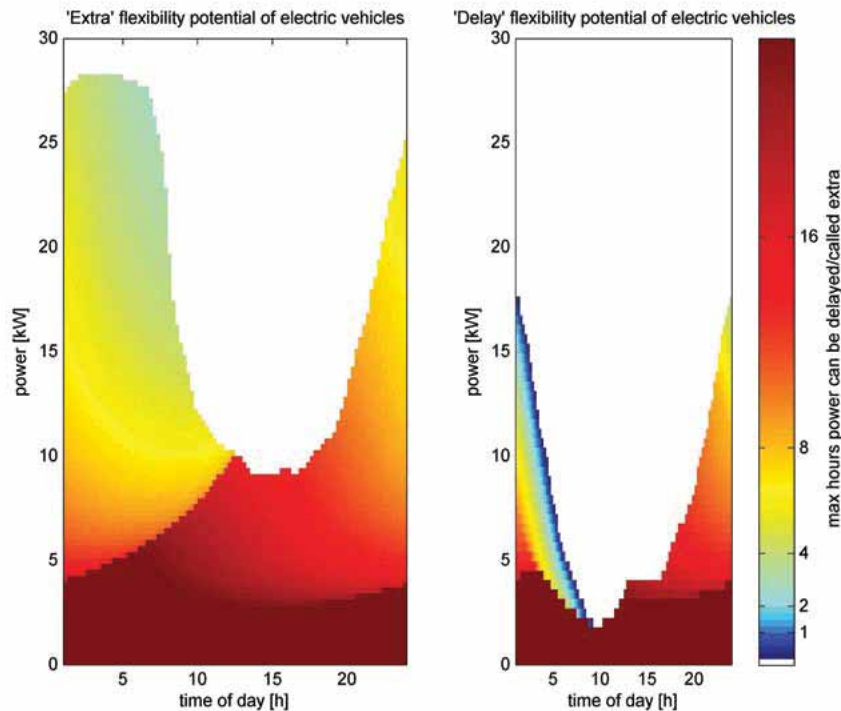

Figure 44: flexibility potential of the 32 electric vehicles analyzed in the pilot test based on the maximum flexibility potential.

Impact on security of supply

Peak electricity consumption during winter traditionally occurs after sunset, at around 6:15 p.m. (Elia). In light of this, delaying consumption until after 10 p.m. would require flexibility for a period exceeding 4 hours.

The maximum amount of power that can be delayed at the winter peak time for at least 4 hours, by using the flexibility offered by **wet goods appliances**, is **60 MW** during weekdays, presuming all Belgian households participate in demand response with their wet goods appliances.

Currently, 18% of Flemish households heat their water using electricity. Extrapolating this to 4.6 million households in Belgium results in a current potential installation base of 830,000 smart electric hot water buffers. Linear measurements showed that 0.25 kW per smart electric buffer (200 liters and 2.4 kW) installed can be delayed at the winter peak time for at least 4 hours. If 18% of all Belgian households were to have such a **smart electric hot water buffer**, this would add up to extra power of **207 MW** that can be delayed during the winter peak.

Electric vehicles allow for maximum delayed power of around 0.2 kW per vehicle for more than 4 hours at the winter peak time, presuming that the vehicle charges at 10 A. As at June 30, 2014 a total fleet of 4,572 electric vehicles was present in Belgium (Federal Public Service Mobility and Transport). This represents **0.9 MW** of electricity consumption that can maximally be delayed for 4 hours, again presuming that all these vehicles charge at 10 A and also that they are used as passenger vehicles.

Overall, the delay potential of residential appliances adds up to **267.9 MW** of power for at least 4 hours. Heat pumps are not taken into account in this analysis, but can also contribute to mitigating the wintertime consumption peak.

A larger electric vehicle fleet, as well as more electric hot water buffers, could significantly increase delay flexibility. However, a larger installation base of these appliances would also increase the electricity consumption peak.

¹Vreg, 2013
²Statbel, 2009

User Fatigue

Response fatigue occurred during the Linear field trial, but this depended to a large extent on the type of appliance, more specifically its interfacing, and on the remuneration model applicable to the participant.

There was no response fatigue for wet good configurations, as shown in figure 45. In-depth interviews also confirmed that technical issues were the main reason why participants (temporarily) gave up configuring their appliances to provide flexibility.

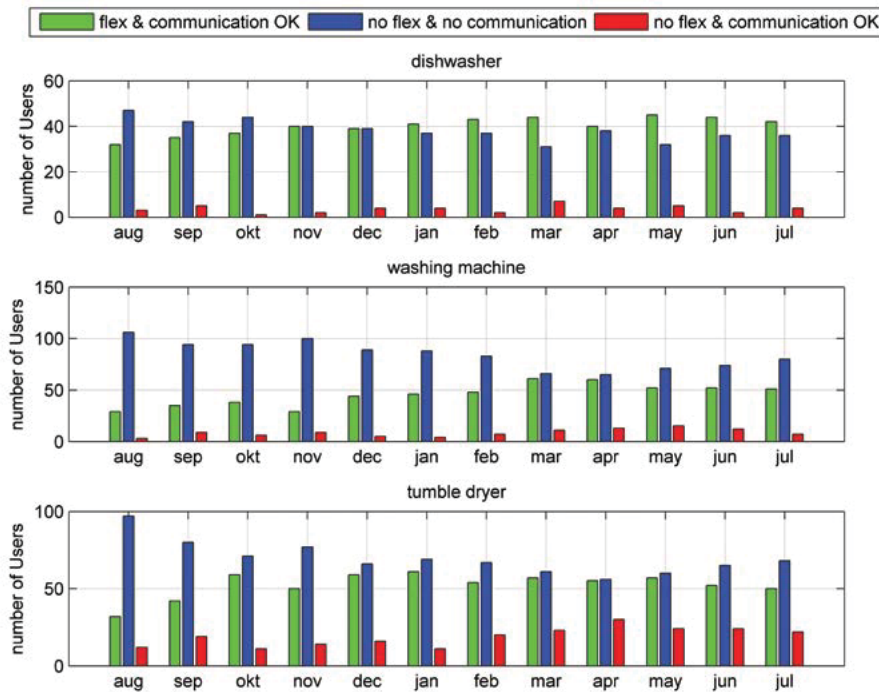

Figure 45: during the field trial we saw a very limited number of people who never tried providing flexibility, or who gave up for the remainder of the pilot. The vast majority of people not providing flexibility were users who were (temporarily) unavailable due to technical issues.

Response fatigue for configuring electric vehicles, however, was very widespread. Specifically, the amount of logged smart configurations was very low compared to the theoretical potential (p.82 Electric Vehicles). The in-depth interviews confirmed that the interface used for setting up the smart configuration for electric vehicles involved an excessive number of overly complex operations.

With respect to response fatigue and remuneration models, we saw no response fatigue in the group of users participating in a capacity fee model. For those participants, who all had smart appliances, the crucial response fatigue factor proved to be the appliance interfaces. This is in clear contrast with the group of users subjected to dynamic tariffs (p70. Dynamic tariffs) who showed limited behavioral changes and a lot of response fatigue. These users indicated that participation required excessive effort and was too invasive and complex.

Based on these experiences we can conclude that to limit response fatigue the effort of participants in configuring appliances needs to be limited to a minimum. Moreover, it is also necessary for remuneration models to reward routine acts to the greatest extent possible.

Enduring behavioral changes require routine acts with low intellectual effort.

User Acceptance

For the field trial, we attempted to create a sample of participants resembling the segment distribution found in the large-scale survey (p.22 Families' Concerns About and Willingness to Adapt to Smart Appliances). Each potential participant had to fill out the same segmentation survey that had been used to develop the segmentation. All potential participants were assigned to one of the four segments. Due to self-selection when inviting participants to join a field trial, mostly Advocates and Supporters signed up. Efforts were made to recruit more Skeptics and Refusers, but this proved to be difficult. The final list of participants contained 82% Advocates, 16% Supporters, 2% Skeptics and no Refusers. At the end of the field trial the segmentation was reexamined to verify whether changes in participants' attitude had occurred during their use of smart appliances in the field trial. This second segmentation showed a more nuanced image of the segments. The proportion of Advocates dropped to 57% (Figure 46), which is still more than half but significantly lower than at the beginning of the field trial. Most of these advocates shifted to the Supporters segment. These persons also had a positive opinion of smart appliances, although it was somewhat more nuanced. There were practically no Skeptics and no Refusers at all at the start of the field trial, but by the end 9% of the participants had been labeled Skeptics and 3% had become Refusers.

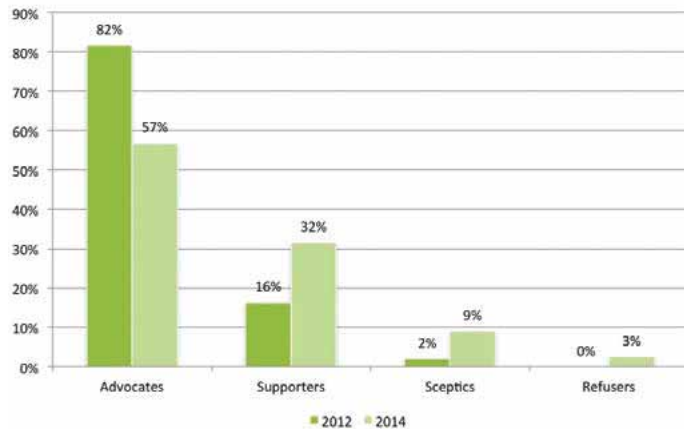

Figure 46: attitude shift towards smart appliances before and after field trial

Mean scores for all segmentation dimensions (Figure 47) all dropped somewhat from the start of the field trial to the end. Participants' opinion on the safety of the appliances, however, did not change. They still considered smart appliances to be safe, although a mean score of 3.75 on a 5-point scale is not extremely high. They also still believed that using smart appliances would not cause them to lose much comfort. Significant drops were measured for control, cost, environment, perceived ease of use, perceived usefulness, intention to use and overall attitude. The expectation to be able to maintain control over smart appliances dropped in comparison to the start of the field trial. This loss of control was mainly caused by a lack of feedback on the actual start/end time of the appliances.

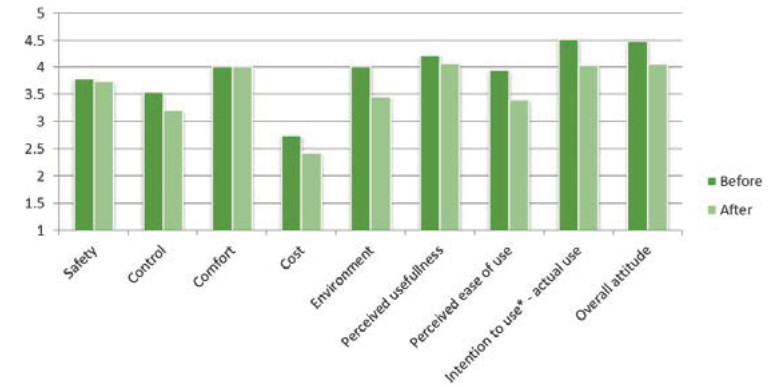

Figure 47: attitude shifts of Linear participants regarding smart appliances

The participants also expected that the cost of smart appliances would be higher than the cost of existing appliances. At the start of the field trial they had high expectations of the environmental friendliness of smart appliances in comparison to existing appliances, but this expectation dropped significantly. Perceived usefulness also dropped, though the mean score was still 4 out of 5. Perceived ease of use dropped more significantly, which might imply that using the smart appliances during the field trial was more difficult than expected. The actual use of smart appliances was also lower than expected at the start of the field trial. The overall attitude towards smart appliances however, remained positive. From these results, it is clear that the high enthusiasm from before the start of the field trial shifted to a more nuanced, yet still positive, opinion regarding the appliances. Technical issues, which were experienced by a substantial part of the participants during the field trial, might be a moderating factor in this regard.

“One of our participating families had its washing machine in a shed in the garden. Since they did not know when the laundry was done, they sometimes walked up to three times through wind, rain or even snow to check whether their device had done its job. An app that tells you whether the device has finished its job might have come in handy for them.”

Jan, Linear support team

This implies that communication about the capabilities of smart appliances, such as demand response, must pay attention to these aspects. Our questionnaire indicated that various test users are not willing to let smart appliances operate when they are not at home or asleep. This is important input for communication about the capabilities of smart appliances, but also for the future commercialization of dynamic pricing systems. If a consumer is not willing to have his or her household electronics operate while not being at home, usage of smart appliances and, for example, dynamic pricing will probably not be considered for a significant number of households. Our research aided in identifying these households, helping to customize communication about this new technology.

Nonetheless, further analysis of user experiences with smart appliances in living-lab settings is necessary. Such research in real-life settings can provide more insights into possible benefits and/or barriers experienced by members of the different segments. Indeed, some benefits and barriers might be hard to identify by means of a quantitative survey.

Laborelec

**Bart Boesmans, Managing Director at Laborelec and
Deputy Director Research & Innovation at GDF SUEZ**

We are very happy to have been part of Linear right from its inception because it was a landmark project in many ways. First of all, Linear was the first comprehensive collaborative effort between the energy industry and the research field in Flanders. This is a prerequisite for being relevant at international level in the fast-moving world of global research and innovation, and it should benefit all the participants in their activities. Moreover, even with relatively modest budgets Linear went the entire distance in implementing flexibility solutions and field testing different business case scenarios, which is quite unique. The results are clear and ready to be used, and I would like to thank and congratulate the teams for the drive and commitment they have shown.



Laborelec, with the support of GDF SUEZ Research & Technology, hosted 4 live aggregation scenarios within the Linear project and quantified the flexibility of the 240 participating households during more than 15 months of field tests. This made it possible to demonstrate the technical flexibility potential of the business to customer market (households) as well as define the most successful home end-appliances for providing that flexibility. Complex application cases, such as intraday wind balancing, gave extremely valuable insights into how and to what extent households can contribute to delivering the flexibility required by the energy systems of the future. Even if changes are needed in the regulatory context to enable deployment, we can unambiguously state that the technological building blocks for business to customer flexibility are now available.

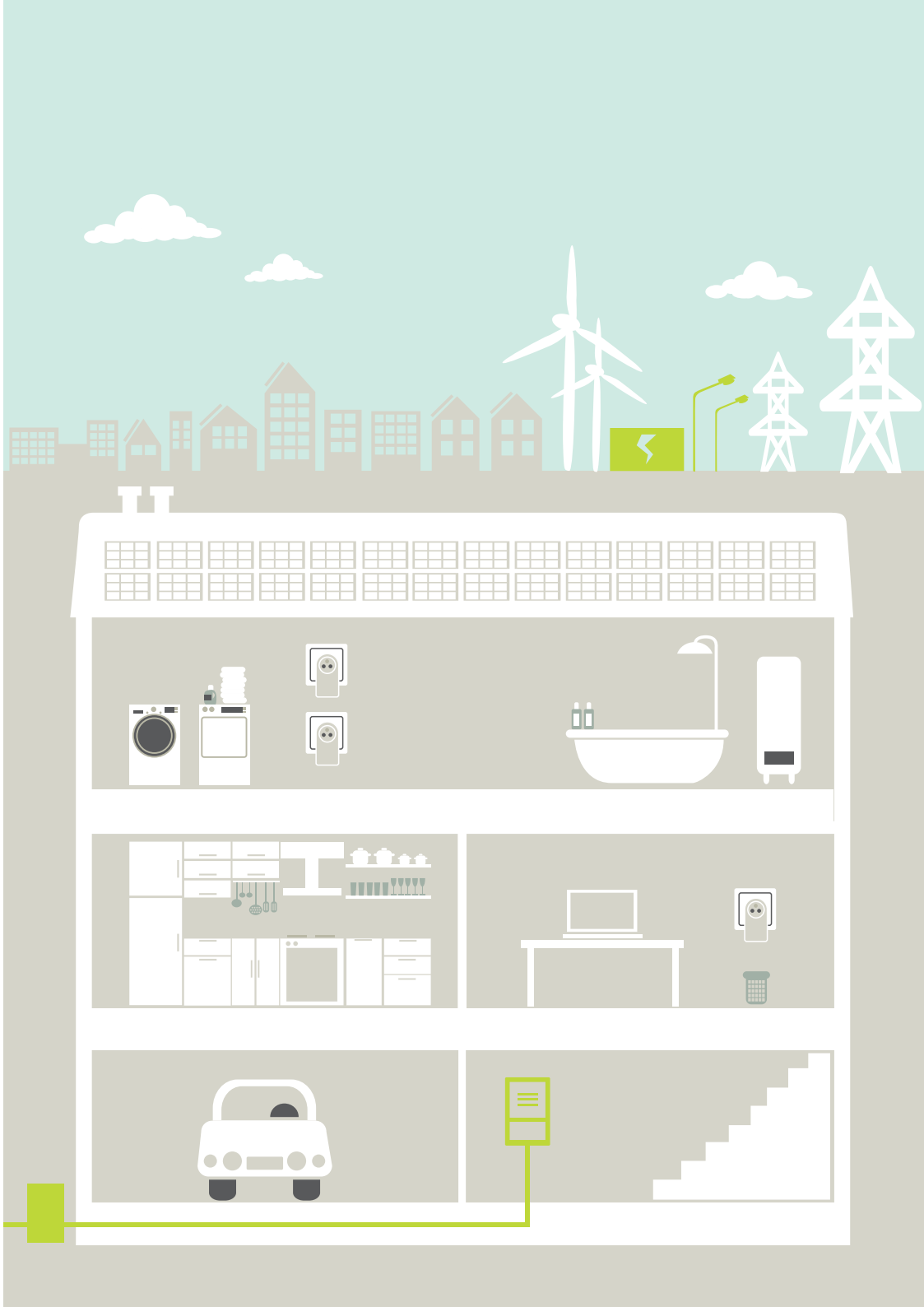

Business Cases

Business Cases

Portfolio Management

Due to its technical simplicity, dynamic pricing is a popular method used in attempts to influence the electrical energy consumption of residential end-users. The simplest and most straightforward application of dynamic tariffs is via manual demand response, i.e. informing end-users of variable prices and relying on those same users to manually shift electrical consumption from expensive periods to cheaper ones. However, a point of debate concerns the decreasing efficiency of such manual schemes due to response fatigue. Here, the end-user tires of continuously checking prices and the ensuing adverse impact on comfort, which results in decreased involvement or a switch to non-dynamic pricing schemes. The alternative is automated demand response, where smart appliances automatically respond to prices and the impact on user comfort is limited to the configuration of these smart appliances. Hence, response fatigue should be less of a concern in this scenario.

Linear fielded and tested both schemes. As addressed in 'Dynamic tariffs', about 55 Linear families participated continuously in a manual demand response scheme, and dynamic pricing was one of the 4 cases in which the flexibility of the smart appliances was implemented.

To what extent are both manual and automated residential demand response suited to respond to dynamic pricing schemes that reflect both the day-ahead balance in the portfolios of, for example, retailers and producers, and the predicted load on the distribution grid?

Linear Dynamic Tariff Scheme

Linear deployed a tariff scheme that divided each day into 6 fixed time zones: midnight -7 a.m.-10 a.m.-1 p.m.-5 p.m.-8 p.m.-midnight (Figure 48). The variable tariff per time zone was based on a dynamic energy and distribution component while the transmission and levies components remained constant.

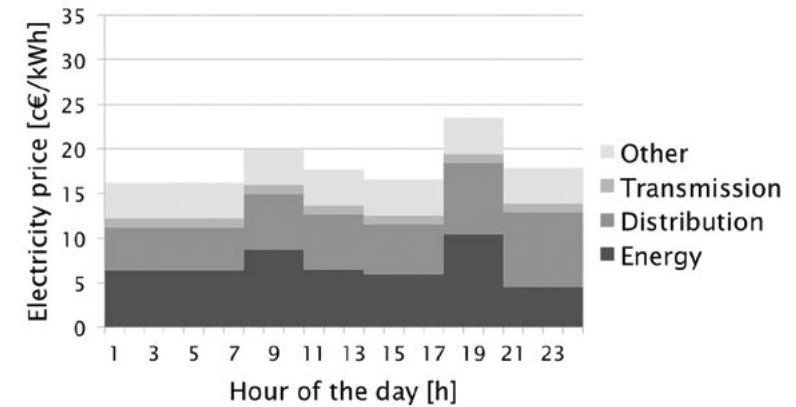

Figure 48: example of the Linear dynamic tariff and its composition for one day.

The dynamic energy component was based on the day-ahead Belpex wholesale market prices, but scaled to reflect a larger share of wind and solar plants in the overall generation mix. The dynamic distribution prices reflected the residential load on the distribution grid. Both components were cost neutral, i.e. if the average consumer¹ did not change his or her consumption pattern then the total energy cost according to the dynamic tariffs was identical to the total energy cost according to a flat tariff of €200c/kWh. Prices for the next day were published at 4 p.m., i.e. after the clearing of the day-ahead market².

¹ The average consumer is defined by the Synthetic Load Profiles, maintained by the VREG (see "Families' Concerns About and Willingness to Adapt to Smart Appliances").

² More details on the Linear tariffs can be found in:

B. Dupont, J. Tant, and R. Belmans, "Automated residential demand response based on dynamic pricing," in Innovative Smart Grid Technologies (ISGT Europe), 2012 3rd IEEE PES International Conference and Exhibition on, Oct 2012, pp. 1–7.

B. Dupont, C. D. Jonghe, L. Olmos, and R. Belmans, "Demand response with locational dynamic pricing to support the integration of renewables," Energy Policy, vol. 67, no. 0, pp. 344 – 354, 2014.

B. Dupont, C. De Jonghe, K. Kessels, and R. Belmans, "Short-term consumer benefits of dynamic pricing," in Energy Market (EEM), 2011 8th International Conference on the European, May 2011, pp. 216–221.

As can be seen in Figure 48, patterns emerged in the tariff structure that are good to keep in mind when interpreting results. Save for a few exceptions, the midnight-7 a.m. block and the 1 p.m.-5 p.m. block were the cheapest periods of the day. During winter, the highest day price could typically be found in the 5 p.m.- midnight blocks. This evening price peak went down as one approached summer time. In summer, it depended mainly on solar and wind production whether the 7 a.m.-1 p.m. blocks or the 5 p.m.-midnight blocks contained the highest day price. **In short, for good performance demand-respond schemes should shift consumption towards the night or afternoon.**

Manual Demand Response and Dynamic Tariffs

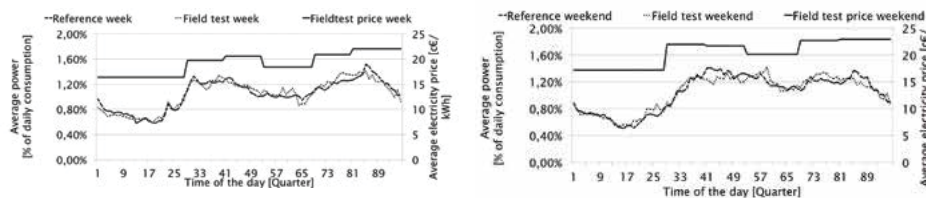

Figure 49: impact of manual dynamic pricing on the average power pattern of households during week (left) and weekend days (right) expressed as percentage of average daily consumption, together with the average electricity price per price block. Reference runs from March to June 2013; pilot results run from March to June 2014.

Figure 49 illustrates average week and weekend Linear household consumption patterns, both for a reference period during which the households did not participate in any demand response scheme and for the pilot period, during which the participants were active and provided with dynamic prices. The share of consumption in the late evening period, i.e. when prices are highest, decreased during the pilot, while the share of the 1 p.m.-5 p.m. and 5 p.m.-8 p.m. blocks increased. No increase past midnight was observed, meaning that - contrary to the automated control - users did not shift to the night blocks.

However, **we observed a lot of response fatigue and Linear user feedback clearly indicated that the Linear pricing scheme was too complex for manual demand response.** We also observed large variations in response per user. Furthermore, there was a consumption reduction of 9% for the pilot period compared to the reference period. Measurements for a control group outside Linear indicated a reduction of 6% for the same period, which means a climatological reduction masked consumption shifts that hampers detailed analysis.

User interviews and questionnaires indicated that the appliances most used to manually shift consumption were dishwashers, washing machines and tumble dryers. In other words, **the potential of manual demand response was a subset of the potential of smart appliances and automated demand response.**

Automated Demand Response and Dynamic Tariffs

Control Methodology

The dynamic tariff control algorithm scheduled each appliance separately such that the energy cost per appliance was minimized while still complying with the comfort settings (Figure 50).

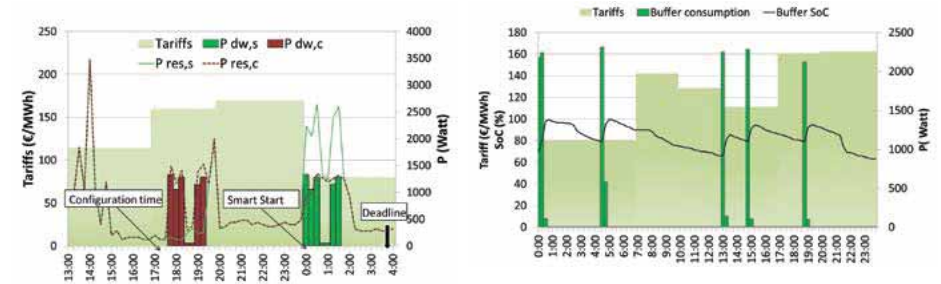

Figure 50: example of the control of a dishwasher (left) and a domestic hot water buffer (right). The consumption of the dishwasher was shifted from configuration time to the cheapest block before the deadline, with a significant impact on household consumption (green line instead of dashed brown line). The buffer was recharged during cheap periods when it reached a state of charge of 80%. During more expensive periods the charging was delayed as much as possible while nevertheless maintaining sufficient warm water in the buffer to cover any immediate consumption peaks.

The primary aim of the control algorithm was to minimize the energy cost of the smart appliances. As the consumption and hence the cost of each appliance is mutually independent, each appliance was scheduled individually based on the prices published and the user's settings. For the white goods appliances, a secondary control criterion was applied to avoid concurrent consumption peaks: dishwashers were started as early as possible, washing machines as late as possible, and tumble dryers at the first moment during which no overlap with other appliances occurred. This secondary optimization took place at cluster level, i.e. for all appliances configured at that time for all users. User settings and prices always took precedence over this secondary objective.

Results

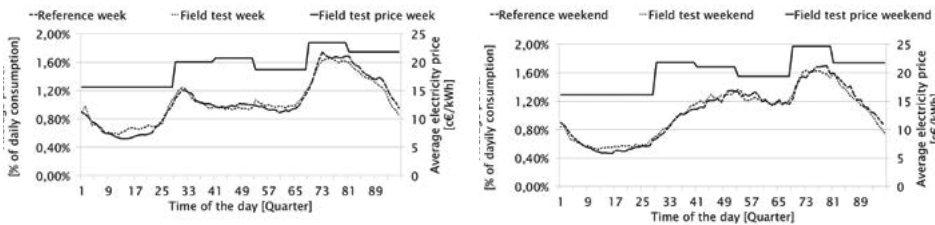

Figure 51: impact of automated dynamic pricing on the average power pattern of households during week (left) and weekend days (right) expressed as percentage of average daily consumption, together with the average electricity price per price block. Reference runs from mid-september to mid-november 2012, pilot results run from mid-september to mid-november 2013.

Figure 51 illustrates the average reference consumption patterns and average pilot patterns during which smart appliances were scheduled based on the dynamic tariffs. The share of consumption during lower price periods increased while the share of the high price periods decreased; consumption shifted from morning to afternoon and from evening to night. At the start of cheap periods, small consumption peaks caused by the smart appliances starting up could be seen. It should be noted that the averaging in Figure 51 masks the clear demand shifts that can be detected when days are studied separately.

In general, automated demand response yielded larger and more predictable demand shifts compared to manual demand response. Consumption also shifted deeper into the night.

Appliance Performance

The performance of automated demand response can be more accurately evaluated at appliance level since the Linear smart appliances only accounted for a limited part of the highly stochastic total energy consumption of the households. Figure 52 and Figure 53 illustrate the clear shift of energy consumption for the smart appliances to the cheaper tariff blocks³.

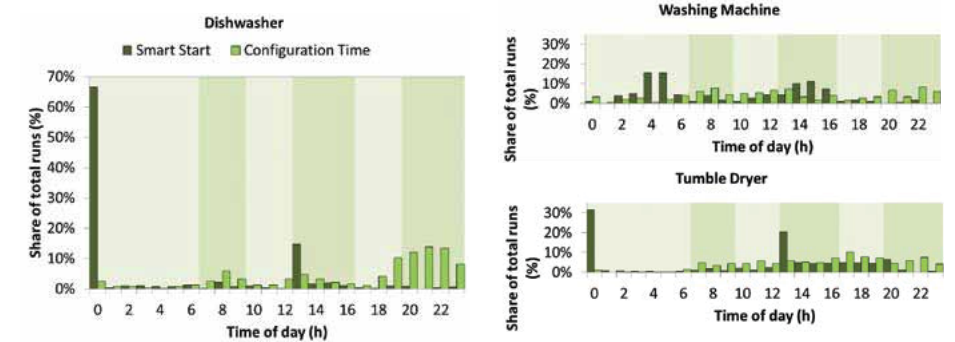

Figure 52: distribution of when appliances were configured by users and when demand response control started appliances, per hour and throughout the day. The wet goods cycles were strongly shifted to the cheaper night and afternoon tariff blocks. Dishwashers outperformed other appliances as they were typically configured in the evening and could more easily be shifted into the cheaper night block. Note also the effect of the control logic designed to start washing machines as late as possible.

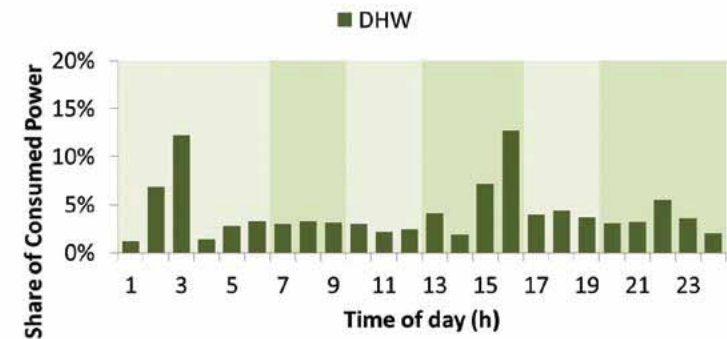

Figure 53: energy consumption share of the smart domestic hot water buffers - when controlled based on the dynamic tariffs - per hour, and throughout the day. A significant share of consumption was shifted to the cheaper night and afternoon blocks.

³ All results in this section are based on a selection of 58 participants and their 117 smart appliances with data from experiments spanning from September 2013 to July 2014. The selection criteria are the correct operation of the demand response system, combined with the availability of validated detailed measurement data.

Dishwashers outperformed tumble dryers and washing machines. Note, however, the high standard deviation. **There was also a large variation in returns per user.** The deciding factor for the returns was the time of configuration, exemplified by the link between a typical evening configuration and larger returns for the dishwasher. As Figure 55 shows, there was also a link with how often a user offered flexibility with a specific appliance; the more a user configured the appliances with a flexible window, the more the (higher-probability) configurations with a higher return outweighed those with a low return, thereby resulting in a better average profit.

The Linear dynamic tariffs were composed such that they were cost neutral compared to a flat tariff of €200/MWh for the average consumption pattern. This implies that the consumption pattern of appliances that were scheduled to coincide with the cheaper tariff blocks should have generated a profit compared to when the flat tariff was applied:

Savings smart start time vs. configuration time (per cycle)	Average savings (%)	Standard deviation (%)
Dishwashers	18.26%	15.29%
Tumble dryers	10.07%	16.07%
Washing machines	9.18%	13.21%

Figure 54: the savings realized when a white goods appliance was started by the demand response system as compared to when it would have been started as the user had configured the appliance.

Profit dynamic tariffs vs. flat tariff ¹	Profit (%) (average for white goods, absolute for Domestic Hot Water (DHW) buffers)	Standard deviation (%)
Dishwashers	18.33%	18.76%
Tumble dryers	8.92%	20.16%
Washing machines	10.97%	18.51%
DHW buffer 1	8.93%	/
DHW buffer 2	5.05%	/
DHW buffer 3	1.97%	/
DHW buffer 4	1.71%	/

¹ For the DHW buffers the entire consumption pattern was used as they were continuously controlled. For the white goods appliances the consumption pattern was composed exclusively of the smart-controlled consumption cycles.

We saw a large spread in the performance of the Domestic Hot Water (DHW) buffers, comparable to that for white goods appliances. No negative returns were observed. White goods appliances outperformed the DHW buffers in relative savings, but the energy consumed by DHW buffers was much higher than that for white goods appliances (Figure 55 and Figure 56) and not all energy consumed by the white goods appliances was while in smart mode. Hence, **absolute savings for a DHW buffer are significantly greater than for white goods appliances.**

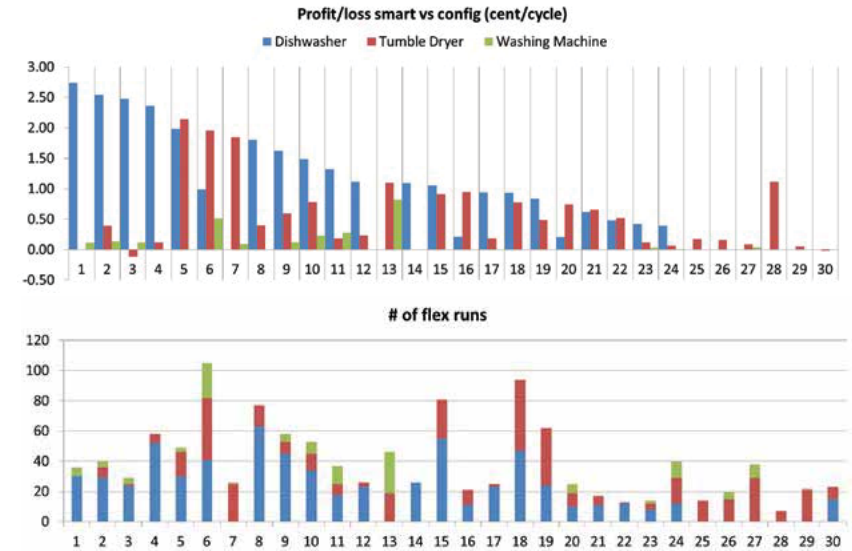

Figure 55: average savings per white goods cycle for the 30 users that offered most flexibility during dynamic tariffs experiments, together with a count of the number of smart cycles.

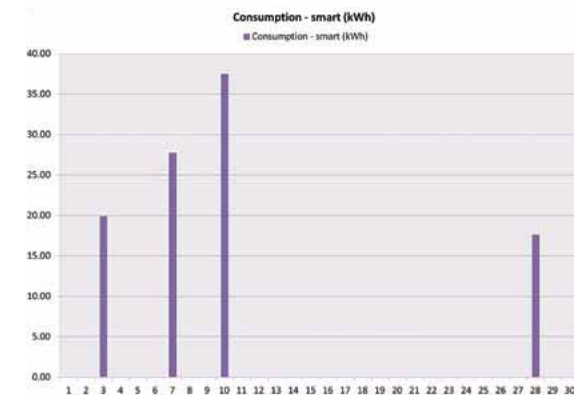

Figure 56: total consumption of the smart DHW buffers during the automated dynamic tariff experiments. The same order as for figure 55 is maintained.

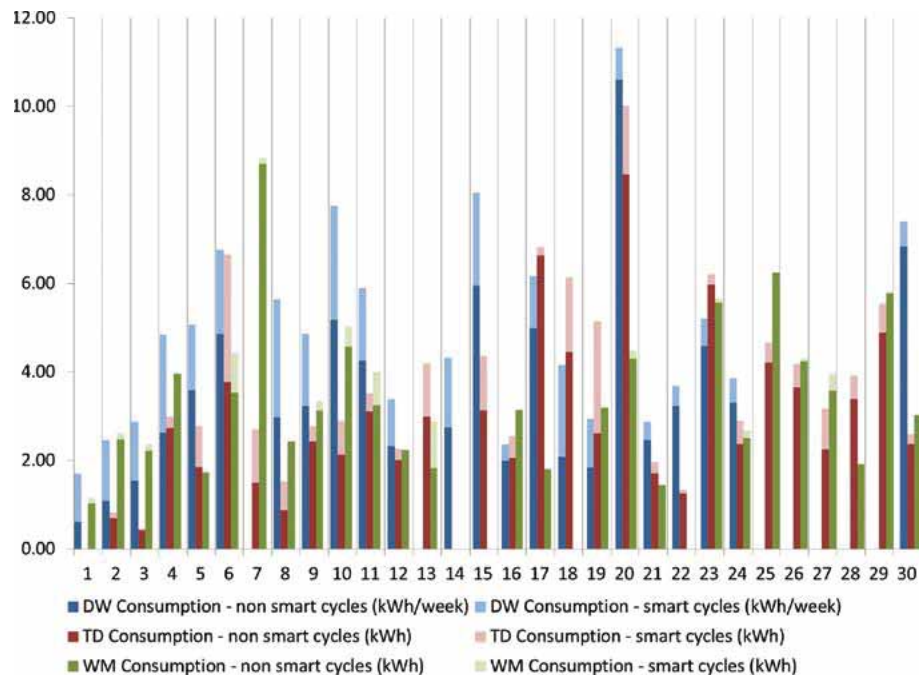

Figure 57: total energy consumption of the smart white goods appliances for the 30 users that offered most flexibility during dynamic tariffs experiments, with the demand response controlled share highlighted. The same order as for figure 55 is maintained. The flexible share is an underestimate, as only the cycles with correct registration and correct measurements were taken into consideration.

Wind Balancing

The Transmission System Operator (TSO) is responsible for the balance between generation and consumption on the grid and has therefore set up a mechanism in order to ensure that the grid is balanced at all times. The Balancing Responsible Parties (BRP) - electricity suppliers, producers, etc. - are expected to balance injection and output in their portfolio every 15 minutes. The TSO manages the instantaneous imbalances that the BRP are not able to control by making use of power reserves supplied by certain grid users. The costs associated with using these power reserves are transferred to the BRP via an imbalance scheme. As such, imbalance tariffs constitute an incentive for them to optimize their portfolio.



Wind power suffers from two problems: it is an intermittent energy source and, additionally, the predictability of wind power is limited. For this reason, a BRP with wind generation in its portfolio has a higher risk of imbalance and so a greater chance of having to deal with imbalance costs.

Can residential flexibility compensate for imbalances caused by the difference between predicted and actual wind production and as such decrease the imbalance cost of the balancing responsible parties?

Potential of Residential Demand Response for Intraday Balancing

In order to assess the potential of residential demand response for wind balancing, we carried out a number of simulations. The analysis started from a BRP's portfolio for the Belgian power system consisting of gas-fired power plants and wind power turbines on the generation side and residential and industrial consumers on the consumption side. The third supply source for consumers was electricity purchased on the wholesale market. The BRP had the following intra-day options available to manage its portfolio:

- modifying the output of gas-fired power plants,
- residential demand-side flexibility.

The BRP then had to pay imbalance costs to the TSO for the remaining imbalance.

As shown in Figure 58, demand response led to a more profitable portfolio. Moreover, higher flexibility levels led to higher profits and scenarios with more wind also contributed to profitability. Total annual profits generated by utilizing domestic demand response, compared to a situation without such a system, ranged from €4 million to €16.3 million (on average €19.13 per active consumer). Note that compensation for the flexibility used was set at 0 in this analysis, that the calculations did not include potential additional expenses required by the BRPs to activate the demand side, and that perfect foresight was presumed. The profits made should thus be seen as an upper limit for the potential of residential demand response in optimizing a BRP's portfolio.

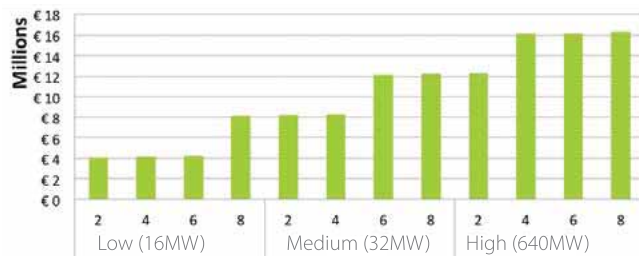

Figure 58: annual profit of the balancing responsible party with demand response compared to no demand response, based on historical market prices for 2012, presuming capacity of 1,250MW for the gas-fired plants, and for 3 different shares of wind in the portfolio: low, medium and high. For each of these shares, available flexibility is expressed as a percentage of total residential consumption. Flexibility levels of 2, 4, 6 and 8% were evaluated.

Linear Base Line Methodology

The Linear project adopted the following stance regarding the role of the BRP versus that of the aggregator: the BRP has the overview of all sources of imbalances, balancing sources and the imbalance market and is best positioned to coordinate balancing at macro level, which is after all its core business. As such, the BRP defines the demand response cluster control set points. On the other hand, management of the individual devices within a demand response cluster - at the micro-level - is the core responsibility of the aggregator and is to be hidden from the BRP. When a BRP calls on demand response to effect a change in consumption, then that change may not be covered by a coincidental change in cluster consumption due to a user action but instead has to constitute a genuine verifiable change with respect to the stochastic consumption pattern. While the consumption profile of single residences is hard to predict (Figure 59), stable consumption patterns emerge when they are aggregated into a large group. As such, all consumption changes caused by users within a demand response cluster have to be separated from the demand response effects in order to manage them within the larger residential portfolio of the BRP at a lower risk level.

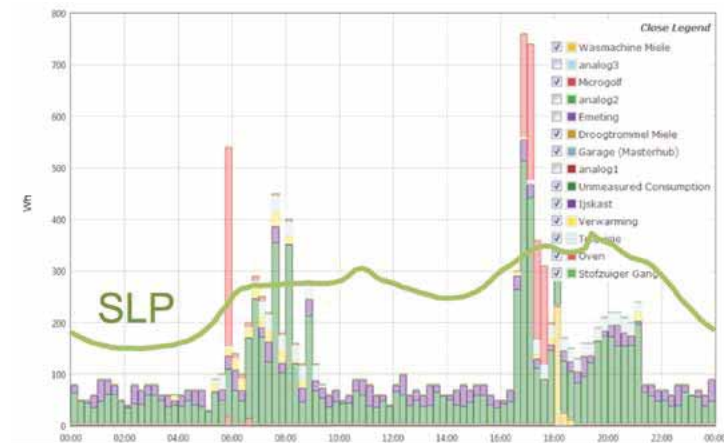

Figure 59: day consumption for a Linear household and synthetic load profile (SLP) for the same day applied for predicting residential consumption. Note the discrepancy between individual households and the average. Note also the impact of oven consumption in the household (in red), the use of which is impossible to predict.

Such a split can be realized by defining a base line, e.g. what would the consumption have been if no demand response control actions had occurred. The two most commonly used base line methods are selecting and averaging representative historic data and/or linear regression. However, both methodologies require sufficient recent measurement data gathered when the system is not influenced by demand response actions. They also presume systems that behave predictably. Neither requirement is met when residential flexibility is used for intraday wind

balancing. Specifically, residential consumption patterns are not predictable and intraday balancing requires continuous control, which means that all historic data is impacted by demand response control actions.

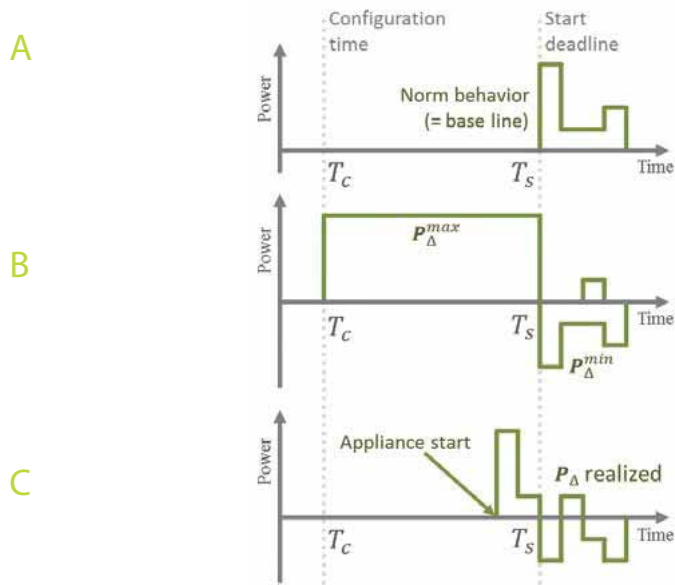

Figure 60: washing machine base line example. Graph A depicts the norm behavior for consumption for a washing machine (starting at the latest possible moment). Based on this, the upper and lower control limits can be derived (B). If the appliance is remotely started, then the consumption change effected is the deviation of consumption relative to the base line, as depicted in C.

In Linear, a new base line methodology was developed based on norm behavior. Norm behavior is a convention on how a smart appliance should behave if no demand response control actions are executed, i.e. it is the default behavior that covers all stochastic user-related variations. The normal behavior for all white goods appliances was to start at the latest possible moment. For domestic hot water buffers it was to stay as close as possible to an 80% state of charge, while for electric vehicles it was to charge at the latest possible moment. Figure 60 shows that the norm behavior defines the base line, that upper and lower control limits can be derived, and that the actual consumption changes attributed to demand response can be calculated. Base lines and control limits can be aggregated at cluster level, where they establish an aggregator interface for the BRP¹.

Intraday Balancing Control

The pilot's intraday balancing setup presumed that demand response was the only source in the BRP's portfolio to compensate imbalances. For this reason the control set point for the residential demand response cluster equaled the total imbalance, which was predefined and based on historic quarter-hour wind imbalance data from part of the wind portfolio of EDF Luminus. This imbalance data was then scaled to align it to the size of the demand response cluster. If the requested volume could not be realized by the demand response cluster, then the cluster control attempted to minimize the resulting net imbalance.

Every quarter hour, the following control cycle was run on the Linear control server:

- Status, user configuration and measurement updates for all appliances in the demand response cluster were collected.
- The change in consumption for the demand response cluster for the next quarter hour with respect to the base line, supposing no new commands were issued, was calculated. Due to previous control actions, this consumption was not necessarily equal to the base line consumption.
- If the wind had been underestimated and an increase in consumption was required, then the impact on the base line was calculated for all sources of flexibility that could be switched on. This impact was the deviation with respect to the base line the sources of flexibility caused if they were activated on the spot, and for white goods appliances it was equal to the length of the program. The appliances were then sorted in increasing order of impact and activated based on this order until the imbalance was corrected.
- Decreases in consumption could only be achieved by switching off the charging of domestic hot water buffers or electric vehicles. If the wind had been overestimated, then these devices were randomly selected and switched off, if the comfort settings allowed, until the imbalance was rectified.

In the remainder of the text, ΔP is the control set point, i.e. the imbalance that must be compensated, and ΔC is the change in consumption achieved. Therefore, ΔC must be as close as possible to ΔP .

¹ A Norm Behavior Based Deterministic Methodology for Demand Response Base Lines, Koen Vanthournout, Wim Foubert, Catherine Stuckens, Bert Robben and Geert Premereur, in proc. of PSCC 2014, the 18th Power Systems Computation Conference, August 2014, Wroclaw, Poland

Pilot Results

Cluster Performance

As can be seen in Figure 61, the asymmetric flexibility of the smart appliances was reflected strongly in the performance of the residential demand response cluster. **When consumption had to be increased due to an underestimation of wind generation, the cluster performed well.** When consumption had to be decreased, however, the cluster underperformed¹.

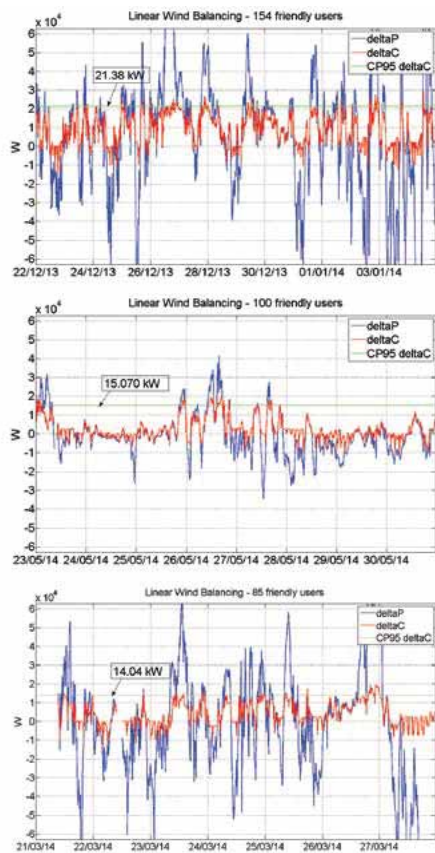

Figure 61: imbalance (Δp , blue) and consumption change achieved with residential demand response (Δc , red line) for 3 weeks, with different cluster compositions (figure 62) and different imbalance scaling settings. Green line is the 95th percentile of the Δc , i.e. the cluster's upper control limit. Δc is calculated using the appliance status data.

¹ Note that the control algorithm does not include any predictive capabilities. If consumption decrease requests can be anticipated, better performance can be expected. However, consumption increases will always perform better due to asymmetric flexibility.

A second important conclusion is that there was a cluster upper control limit which was strongly correlated to the size of the cluster (Figure 61). For the Linear cluster composition (Figure 62), primarily consisting of white goods appliances and a limited number of domestic hot water buffers, this **upper control limit was approximately 150 W per household**. This figure remained stable for the different cluster sizes in the various Linear wind balancing experiments.

Measurement period	12/22/2013-01/04/2014	03/21/2014-03/27/2014	05/23/2014-05/30/2014
# families	154	85	100
# washing machines	39	33	44
# dishwashers	48	23	49
# tumble dryers	34	22	39
# DHW buffers	8	4	11
# electric vehicles	0	3	4

Figure 62: cluster composition used for figure 61 and figure 63.

Appliance Performance

Figure 63 shows the cluster performance for one standard day. As in Figure 61 the cluster's asymmetric performance is clearly visible, especially for the white goods appliances.

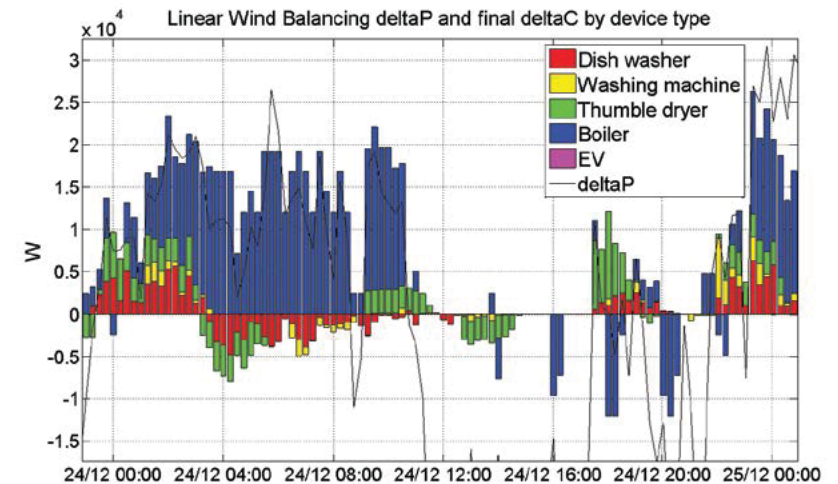

Figure 63: wind imbalance Δp and the cluster performance Δc , per device type and based on device status data, for 03/24/2014.

The control system used the smart appliance's status data to calculate the base lines and the ΔC contributions. The data typically used for settlement was measurement data. Delays in the execution of control commands, communication problems during which no or limited status info was available, inaccurate status information, errors in the power consumption estimates for white goods appliances, as well as comfort overrule switching for domestic hot water buffers, all had an impact on performance as perceived by the control system versus what was actually measured. Figure 63 and Figure 64 are examples from the control system's point of view, and we can see that especially domestic hot water buffer contributions were overestimated. Figure 65 is based on measurements and shows the actual contribution of each appliance.

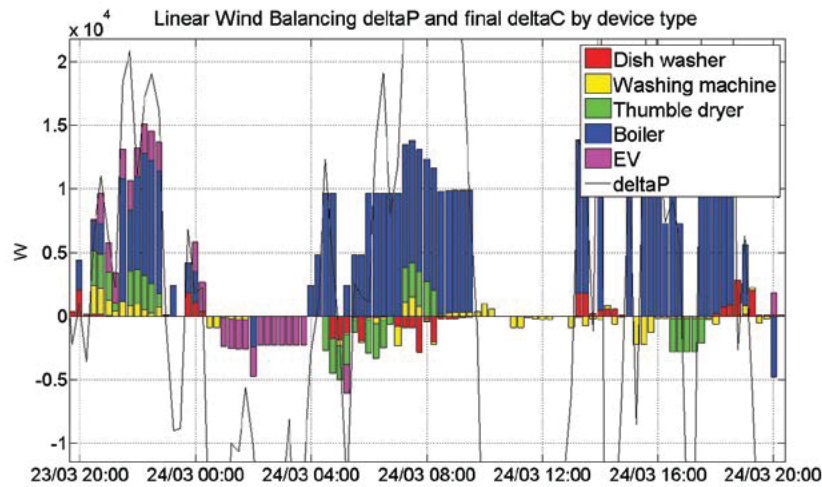

Figure 64: wind imbalance Δp and cluster performance Δc , per device type and based on the device status data, for 03/23-24/2014. this example includes the smart charging of an electric vehicle with a departure time of 8:00 a.m. Norm behavior is to charge from 12:30 a.m. until the departure deadline. The car is charging between 4:00 a.m. and 8:00 a.m., resulting in a 0 Δc , except for 15 mins at 5:00 a.m.

Despite their limited numbers, **domestic hot water buffers were the workhorses** and were responsible for a large share of imbalance corrections. As illustrated in Figure 65, this holds for both positive and negative imbalances. The domestic hot water buffer's norm behavior was implemented as a bi-hourly check: if the buffer's state of charge was below the 80% reference at the start of the even hours, it recharged to 80% (see p.50 Smart Electric Domestic Hot Water Buffer). This implementation of the norm behavior caused the buffers to normally charge at the start of those even hours, and this implied in turn that this was when load decreases could typically be achieved with respect to the norm behavior base line, as can be seen in Figure 65. It also led to domestic hot water buffer rebound alignment with the even hours.

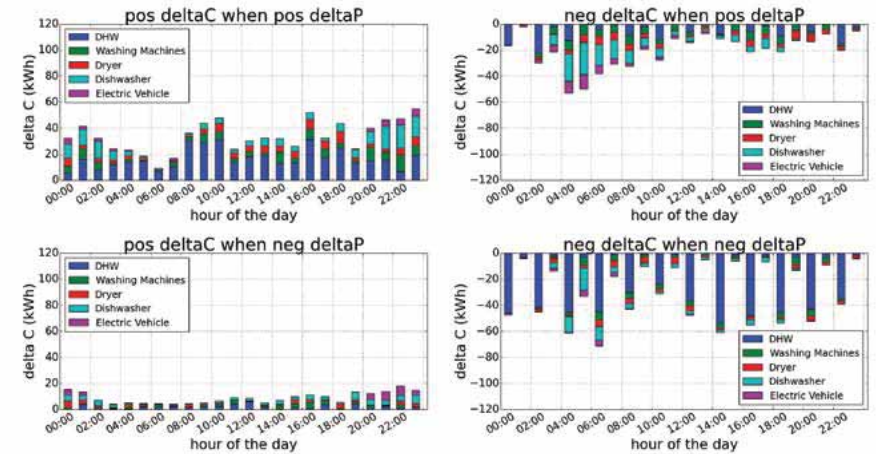

Figure 65: total summed positive and negative contributions in kWh of each device to Δc , per hour of the day and split per the sign of the imbalance (Δp), based on the appliance consumption measurements during the same 3 periods presented in figure 61. if Δp and Δc have the same sign, the contribution was correct (top left and bottom right), if the sign differs, then this indicates unwanted rebound (top right and bottom left). Note that this encompasses clusters composed primarily of white goods appliances, a limited number of domestic hot water buffers and a limited number of electric vehicles, the latter of which suffered from response fatigue. As there was no strong correlation between wind imbalance and time of day, the total amount of imbalance corrected per hour and per device is a good indicator of the availability and performance of the flexibility sources. Base lines and appliance contributions were calculated using consumption measurements for the smart appliances.

Performance of the **white goods appliances** was in line with their typical flexibility pattern (p.76 Flexibility offered by the participants): they **contributed mainly when consumption increases were required**, and in a very limited manner in the opposite situation (Figure 65). **Their contribution was also greater in the evening**, especially as regards dishwashers. However, **rebound was significant**. Especially in the early morning, a clear rebound peak was visible, caused by appliances that had started earlier in the night and that needed to be compensated for at those moments when increased consumption was still required (Figure 65, top right). This also worked the other way: the full contribution of white goods to negative imbalances was due to the rebound of earlier activation coinciding with the need for consumption decreases. There is an opportunity here: adding predictive capabilities to the cluster control could improve rebound management and exploitation. White goods appliances also exhibit positive rebound, i.e. once a white good appliance is started it has to finish its program, even if an increase in consumption is no longer needed. As the time constant of the imbalance was large, the effect of the latter rebound type remained limited.

As discussed in (p.82) Electric Vehicles, users only configured their electric vehicles a limited number of times. However, as the example in Figure 64 shows, electric vehicles did perform well for the balancing case when smart charging was available. In line with other findings on electric vehicles, electric vehicle contributions mainly took place at night and in the evening.

Impact of Wind Balancing on the Low-voltage Grid

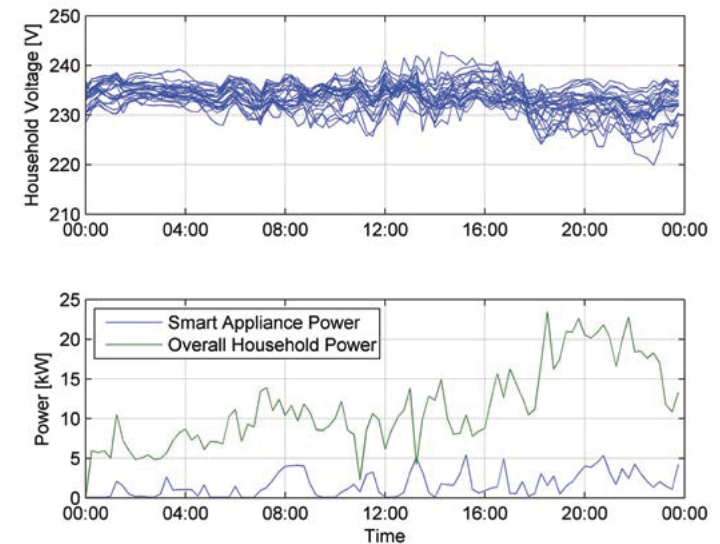

Figure 66: measured voltage for 23 Linear households participating in wind balancing during one day (05/12/2014), together with the total power demand of those 23 houses and the power demand of the smart appliances activated by wind balancing.

During the Linear pilot, the impact of the wind balancing business case on line voltage and transformer aging was very limited. Specifically, maximum activated power demand from the smart appliances remained limited compared to the overall maximum power demand of the households, as illustrated in Figure 66. There was no particularly noticeable effect on voltage profiles or on the aging of the transformer that can be correlated to wind balancing. In fact, the average aging factor of the Bret-Gelieren transformer during the wind balancing experiment, for both base-line consumption and measured consumption with demand response, was 0.1525. However, if more appliances, and in particular appliances with a greater power demand, participate in wind balancing or similar business cases, care must be taken that synchronized activation/deactivation does not aggravate consumption/production peaks, respectively.

Transformer Aging

Low-voltage transformers must be replaced when the maximum connected load exceeds the unit's absolute load limits or when the paper insulation of the windings has reached the end of its lifetime. The absolute load limit, which is in the range of 100%-160% of the transformer's rated load, is rarely an issue since low voltage networks are typically designed in such a way that voltage problems will occur before transformer overloading. As such, this case can be considered a sub-case of the Linear voltage control business case and for this reason it is not further considered here.



Figure 67: installation of measurement equipment at an Eandis transformer.

Aging of the unit's paper insulation, on the other hand, is an exponential function of the temperature in the transformer. Using demand response to shave the temperature peaks, which are correlated to persistent high currents levels, can increase the life of the transformer, which in turn allows for the postponement of investments for replacements or upgrades.

Can residential flexibility avoid temperature peaks in transformers and thereby increase the life of low-voltage transformers?

Setup and Control

Every 15 minutes the control server received external temperature, oil temperature, current and voltage measurements from the transformers in the field (see Figure 68). These values were the average values for the past quarter hour. Using these measurements and based on the IEC 60076-7 model, the hotspot temperature was calculated, which in turn was used to calculate aging. This standard's reference hotspot temperature is 98 °C for non-thermally upgraded paper and 110 °C for thermally upgraded paper. It is presumed that this corresponds to an aging factor of 1 and a normal insulation life of 20.55 years¹. The calculated aging factor expresses the aging relative to this default aging. However, the transformers deployed in the Linear pilot were over-dimensioned and stayed well below these limits and no significant aging was observed. To artificially increase aging, a hotspot temperature limit of 60 °C was used in the Linear experiments and the resulting aging is shown in Figure 69.

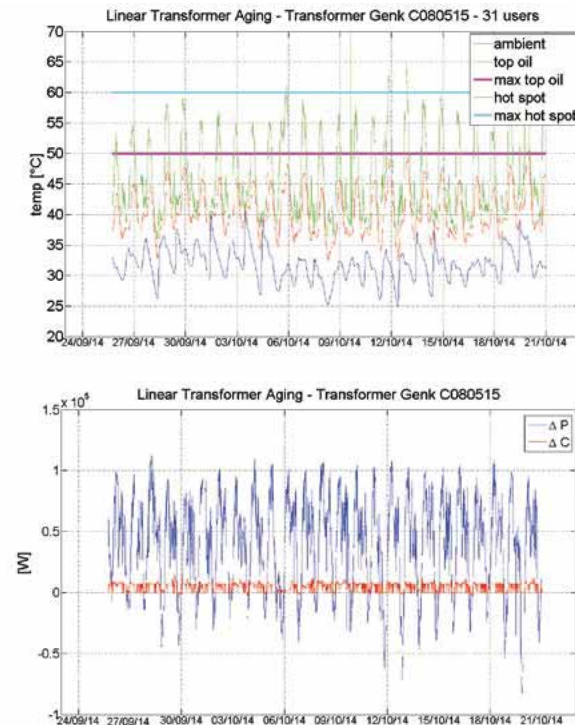

Figure 68: Bret-Gelieren transformer measurements, control set points (Δp) and demand response consumption changes (Δc) for the period 09/25-10/20/2014.

¹IEEE Std C57.91™-2011

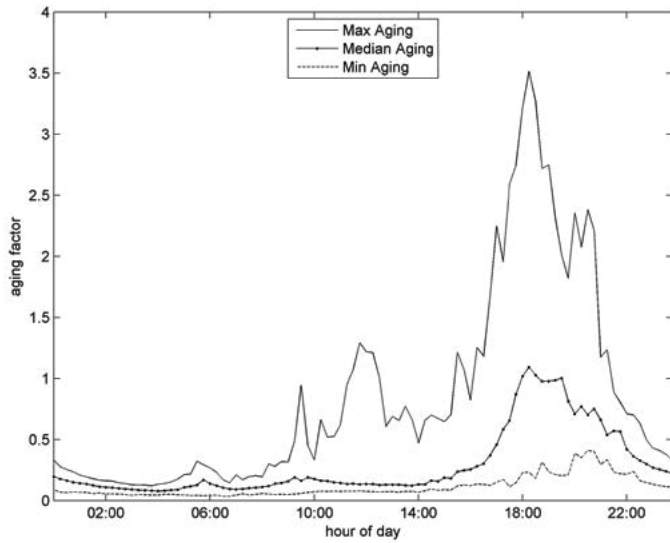

Figure 69: minimum, maximum and median aging of the bret-gelieren transformer throughout the day (09/25-10/20/2014, with 60 °c reference hotspot temperature). Greatest aging occurred during the evening consumption peak.

The quarter hour control loop executed the following steps: first, the hotspot temperature was calculated. Then, based on the temperature history and current measurements, a 180-minute forecast of the hotspot temperature was drawn up. Based on this data the change in consumption required to lower or increase the hotspot temperature to 60 °C was derived. The same control algorithm as for the wind balancing case was then used, with the demand response ΔP control set point set to this 60 °C consumption change (see p.103 Wind Balancing). The resulting behavior was that consumption was stimulated when the temperature was low and decreased when the temperature was high (see Figure 68). Most of the time the ΔP set points were much higher or lower than what the cluster could provide. The goal here was not to track ΔP as closely as possible as for the wind balancing case, but rather to shift as much consumption as possible to periods with a low transformer temperature.

Pilot Results

Control Performance

As aging occurs primarily during the evening peak (Figure 69), the control's performance can be measured by its success in shifting consumption away from the evening period. For white goods appliances, the performance was good, as can be seen in Figure 70. However, the same figure also illustrates that the performance for the buffers was lower, i.e. although consumption during the evening peak was lowered and postponed into the night, peak time consumption remained significant.

Since our measurements demonstrated a strong correlation between evening peak and aging, these heuristics were able to be used to both simplify and improve the control algorithm. The cluster could then prepare for the approaching evening by scheduling white goods appliance cycles before and after the peak, and by fully charging domestic hot water buffers in the afternoon.

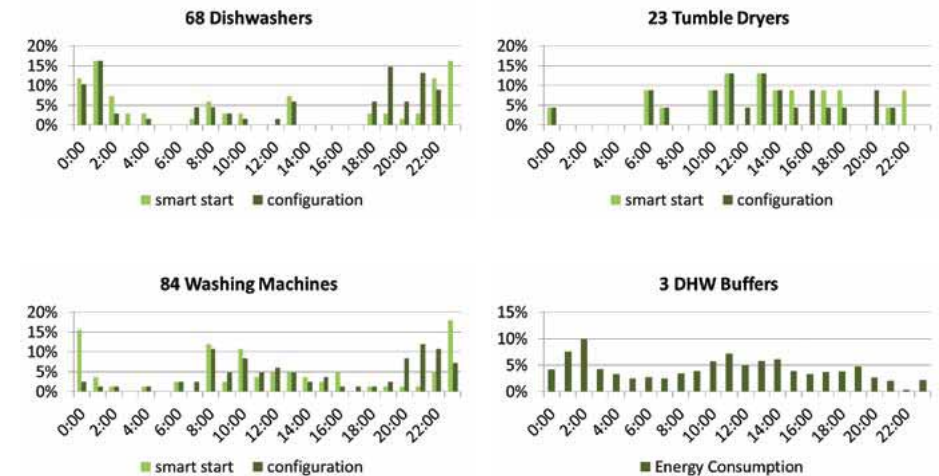

Figure 70: share per hour throughout the day of the configuration and remote smart start events for the white goods appliances, and share of the consumption per hour for the domestic hot water buffers (09/25-10/20/2014). Consumption was shifted away from the evening peak.

Impact on Transformer Aging

To measure the impact of the demand response actions on the life length of the transformer, the consumption change effected by the control, ΔC , is calculated, using the same norm behavior base line methodology as designed and used for the intraday wind balancing case (see p.103 Wind Balancing). For both the consumption profile with demand response (field measurements) and without the demand response impact (field measurement with ΔC subtracted), the transformer aging is calculated. For the Bret-Gelieren transformer, during the period from 24/09/2014 to 20/10/2014, the average aging with demand response was 0.32789. Without demand response, it was 0.32915. In both cases, this average aging factor translates to a life length of approximately 62.5 years (IEEE model). With the use of flexibility, the transformer lasts about 3 months longer.

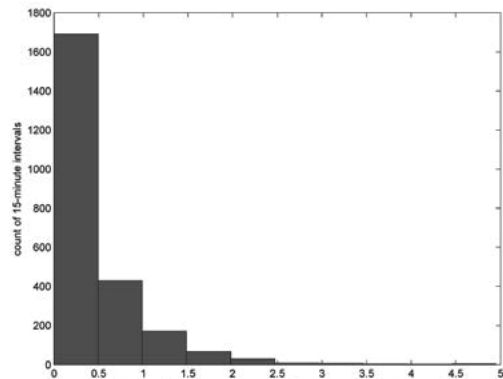

Figure 71: flexible load as a percentage of the total transformer load, not counting zero values (per quarter hour).

The reason the improvement was so small is the lack of sufficient flexibility, as illustrated in figure 71. There were 160 households connected to the transformer and the demand response cluster composition was 14 washing machines, 14 dishwashers, 7 tumble dryers and 3 domestic hot water buffers¹. In the vast majority of situations less than 0.5% of the transformer load was shifted.

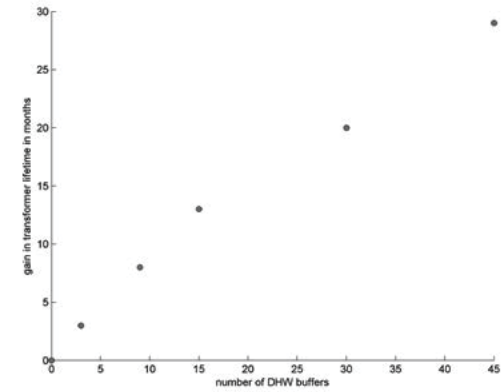

Figure 72: life length increases if more domestic hot water buffers connected to the transformer were controlled. Life impact calculated by scaling the measured contribution of the 3 domestic hot water buffers.

Figure 72 shows the life length increase which would have been achieved if more domestic hot water buffers - the devices with the greatest power demand - had been controlled by the demand response system. With 30 smart domestic hot water buffers, life would have increased by about 20 months. As explained earlier, however, this is an underestimation since control can be improved. Nevertheless, when compared to the total life of a transformer the improvements remain modest. For good results a sizable share of the total consumption connected to the transformer would have to be under the control of the demand response system, which in turn implies that almost the total flexibility potential must be addressed.

¹Smart appliances not in operation during the transformer experiment are excluded.

Line Voltage Control



Figure 73: intelligent meter

Due to the increased amount of distributed renewable energy sources, distribution system operators are facing more complex power flows and increased (local) peaks in production and consumption, and this is influencing (local) voltage. For the line voltage control business case we developed a local voltage control mechanism to mitigate over- and under voltages, as measured at the household connection to the low-voltage distribution grid. Controlling the voltage locally, so on the household premises using the flexibility of the household, could help to maintain the grid within acceptable limits while at the same time minimizing, deferring or even making unnecessary the need for grid capacity upgrades.

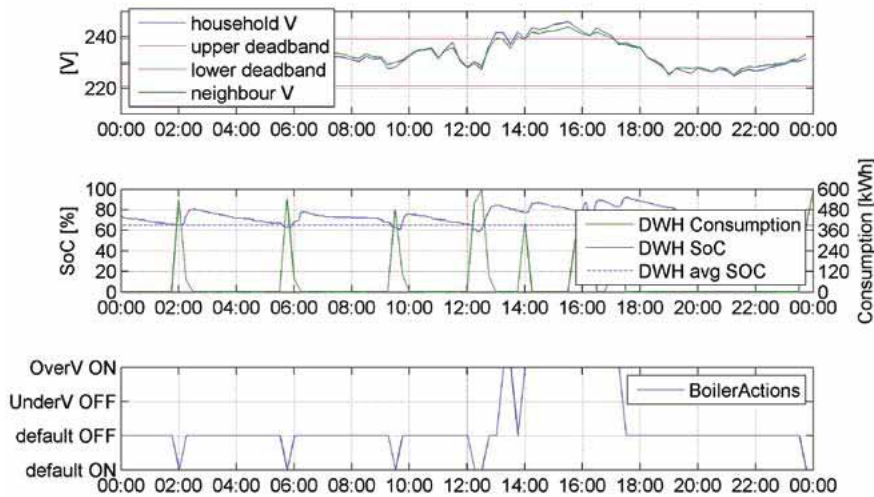

Figure 74: illustration of the behavior of the control system in a household with a smart domestic hot water buffer showing the control signals, measured voltage and control system deadband limits, and hot water buffer state information.

Linear's voltage control mechanism uses the readily available flexibility of the residential smart appliances provided and has as its main advantage that it does not require a communication network between the different households that are part of the low voltage network. In order to steer this flexibility, the control system merely requires communication between the smart appliances within a household and locally available measurements such as the household supply voltage which a smart meter can provide.

Can we prevent voltage deviation issues in local grids?

The philosophy behind the developed control system is the well-known droop control, where active and/or reactive power is used to control voltage and/or frequency deviations. The control system bases its decision to switch on or off a certain smart device using the measured voltage for the previous time step. If an overvoltage is detected, and devices are available within the household that can be switched on, the control system gives the command to switch on. An analogue procedure is followed at undervoltage instants. If no under- or overvoltages are detected, the devices switch on/off according to predefined default behavior. Switching is based on a merit order, in turn based on the state of the smart appliances and on the measured voltage.

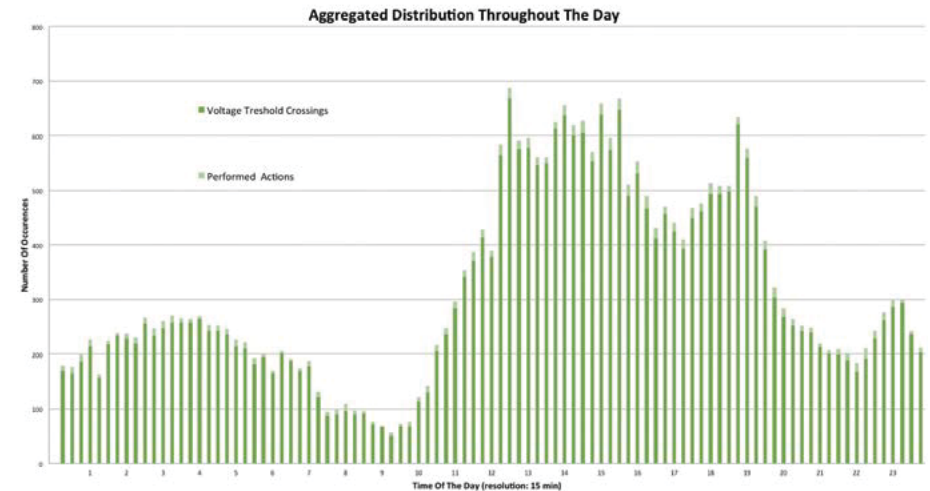

Figure 75: aggregated distribution by time of the day for all voltage threshold crossings and corresponding fractions of voltage control actions. This indicates the lack of available flexibility at the right moment.

The voltage control algorithm was rolled out in 86 households starting in December 2013. The field test clearly shows that the readily available flexibility of the residential smart appliances was insufficient for the voltage control system to have a considerable impact on local voltage.

Moreover, we noticed that the primary source of flexibility used by the voltage control system were domestic hot water buffers. Although many more white good appliances were available, the flexibility of the white goods was mostly given at inadequate times, whereas the hot water buffers were available for control system actions throughout the entire day.

An additional advantage of using hot water buffers for local voltage control is their high power. The result is noticeable voltage drops of 3-5V (at a grid impedance of approximately 0.37 Ω) when the buffer is switched on at overvoltage instants. **The effect of voltage control actions by a domestic hot water buffer is even measurable on the voltage of neighboring households.**

Still, the flexibility of domestic hot water buffers also has its limits: for example, when they are fully charged no extra overvoltages can be eliminated since the buffer cannot be switched on.

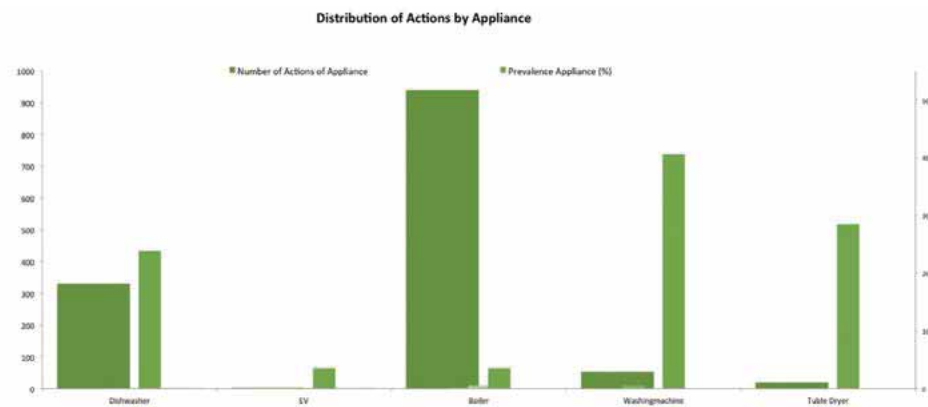

Figure 76: amount of actions taken by each type of device compared to the prevalence of the appliances in the study. Notice the large benefit for smart boiler systems

To conclude: we can state that the Linear voltage control mechanism is a viable option for controlling local voltage if there are enough appliances connected that have flexibility available continuously throughout the day, as well as relatively high power. Examples of this are domestic hot water buffers or other thermally buffered systems.

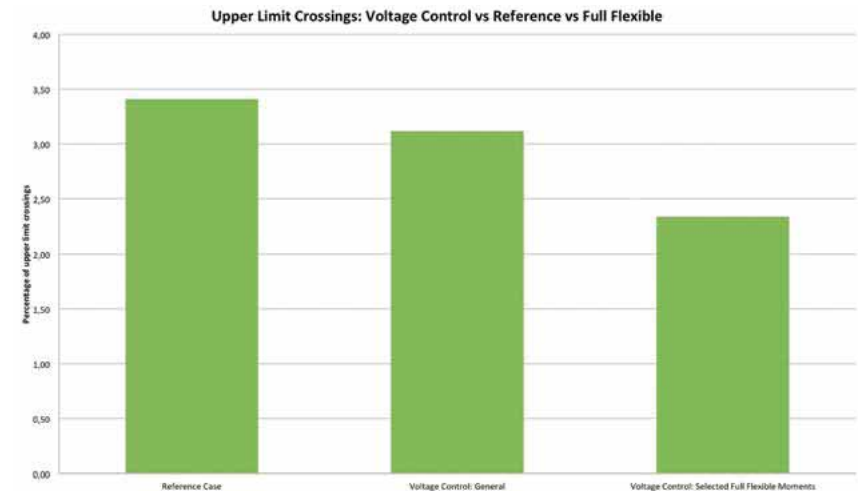
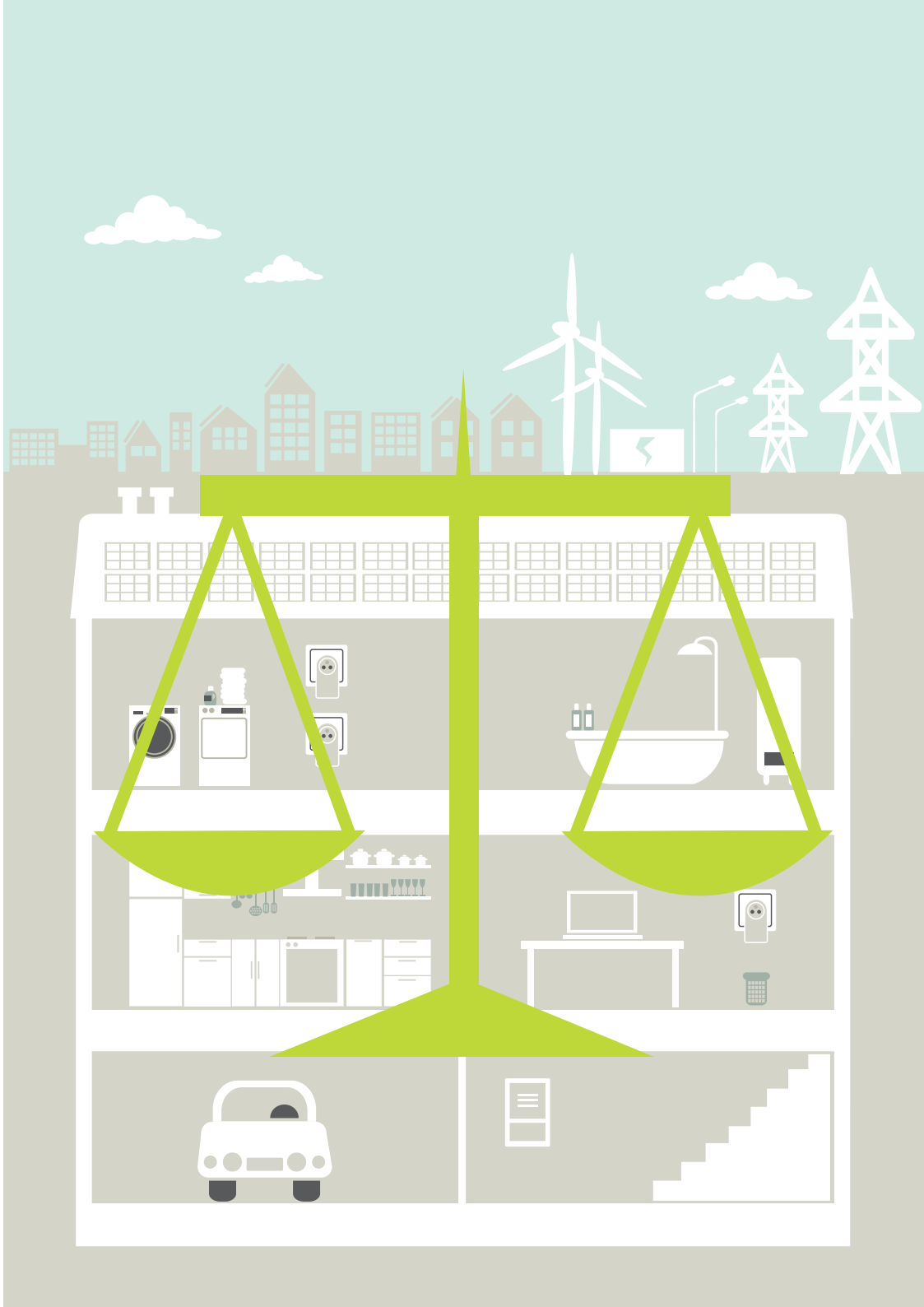

Figure 77: the relative number of upper limit crossings of a predefined voltage level for the same households on different control programs during comparable weather conditions. Compared are the amounts of upper limit crossings for a default case versus voltage control.



Regulatory Aspects

Regulatory Aspects

Introduction

Just like any other sector, the power industry is subject to a set of rules and principles imposed by policymakers. Their objective is to adjust the outcome of the activities of freely interacting corporations based on the idea that free markets are subject to inefficiencies which can be harmful to society as a whole, and which may hinder the development of welfare-enhancing technologies. At the same time, however, regulation (or the lack thereof) by itself can form a barrier to crucial changes in a given industry. While it can be argued that implementation of demand-response for residential consumers was at first primarily a technological issue, nowadays the greater challenge may lie in integrating these new mechanisms into the existing regulatory framework.

Regulatory Framework

Historically, electricity markets in Europe had been characterized by a top-down organization, with the generation side offering the resources and flexibility to keep the power system in balance. During the 1990s, however, the European Union set in motion a continuing process of liberalization and unbundling. This allowed markets for flexibility to emerge in such a way that decentralized generation and even consumers could also actively participate and compete with traditional sources. This process was framed within the more general EU energy policy objective of establishing an integrated internal market based on security of supply, competitiveness and sustainability.

Initially, this change was supported by the European institutions in the First Energy Package, which was later amended by the Second and, most recently, the Third Energy Package of 2009. These documents (including 2009/72/EC) provide a legal basis for the organization of European electricity markets, and explicitly call for more active consumer participation. Among other things, an 80% roll-out of smart meters is proposed for countries with a positive long-term cost benefit analysis. Furthermore, the EU issued the Energy-efficiency Directive (2012/27/EU) in 2012. This Directive puts an even stronger emphasis on active demand, recognizing it as an instrument for accomplishing the EU energy-efficiency objectives. Additionally, the Directive examines the legal provisions relating to other relevant matters such as privacy, data security and consumer protection.

Depending on the instrument, European laws are directly applicable in the Member States, or they need to be transposed into national law within a certain timespan before officially coming into force. Several Belgian (federal and regional) legal provisions are relevant to the Linear demand-response system, including the Electricity Law (of April 29, 1999), laws on privacy, data security and consumer protection, the Energy Decree, and the technical codes applicable to the distribution and transmission of electricity.

Until recently, the regulatory framework in Belgium still largely presumed a market model where flexibility is offered by the generation side. Demand response by residential users, despite never being explicitly prohibited, was not recognized or facilitated by the regulator. However, during the last few years legal provisions in Belgium have been starting to show signs of change in this respect, fueled by industrial support and EU energy policy. In particular, a number of definitions of new smart grid concepts (e.g. aggregator, demand-side management etc.) have been included in the national (and regional) laws and codes. Furthermore, cost-benefit analyses with regard to smart meters have been performed, and new balancing products have been created (e.g. R3 DP, APP, etc.) by the transmission operator to allow for the participation of loads and generating capacity connected to the distribution grid. These developments clearly indicate a shift towards more demand-side participation, as well as increasing regulatory acceptance. Nevertheless, a number of regulatory hurdles still need to be overcome before demand-response for residential consumers can be implemented.

Regulatory Challenges

Market Roles

Perhaps the greatest issue that needs to be addressed concerns the roles and responsibilities of new and existing players on the electricity market. Current competences need to be reviewed and expanded where necessary, and distribution system operators, for instance, will likely need to play a more active role in the future. On top of this, a more thorough demarcation of the competences of aggregators is crucial given the importance of intermediaries when dealing with a large number of small consumers. Besides the need to define new roles, the question arises as to how to deal with their interaction. Demand-response activations may have a significant impact on suppliers (e.g. their sales volume and costs) and the balancing exercise of balance responsible parties. The development of adequate compensation mechanisms is critical in this respect. Furthermore, accounting for the technical properties of the grid and the creation of priority rules between market and technical flexibility seem inevitable. For example, simultaneity of market signals in a local area could lead to network problems such as congestion, thereby requiring the distribution system operator to define certain limits.

Market Entry

Current regulations typically impose minimum requirements on services in order for them to qualify for participation in wholesale markets. Examples include fixed trading charges (e.g. membership fees, entrance fees, etc.), minimum trading volume and minimum available capacity. These trading conditions may hinder the ability of smaller players (e.g. emerging aggregators) to participate.

Regulation of Prices and Tariffs

Active demand-response inevitably requires some form of signal to the consumer and/or (financial) compensation. Dynamic pricing (time-of-use) therefore plays an important role in its implementation, but at the moment it is substantially limited by Belgian legal provisions. Having a pricing structure consisting of several time blocks with different prices during the day is allowed (e.g. day and night tariffs) provided that adequate metering equipment is available, but continuous revision of these prices on a daily basis, for instance, is prohibited by regulations regarding variable contract types. Price indexations are subject to a maximum frequency of four times per year, and they need to be communicated to the regulator for approval.

Another aspect that comes into play is the distribution grid tariff. Nowadays, this tariff makes up a significant part of the final retail rate, and its design can therefore have an effect on the effectiveness of demand-response products based on dynamic pricing. For instance, the tariff structure can lead to the neutralization of market signals when there are conflicting interests between suppliers/aggregators and grid operators. More generally, a poorly designed tariff can lead to technical problems when it encourages sub-optimal grid usage (e.g. local overinvestment in distributed generation). On the other hand, socio-economic problems ensue when the tariff leads to unacceptable cross-subsidization.

Remuneration of Grid Operators

Nowadays, the remuneration mechanisms for distribution system operators are revenue-based. Revenue caps based on historical expenses, trends and benchmarking techniques provide an incentive for cost efficiency. Only certain exogenous expenses are exempted from this cap as they cannot be controlled. Despite the numerous advantages of this remuneration mechanism, there are a number of caveats relating to innovation. Revenue allowances are largely based on historically incurred costs, and so pay little attention to the future needs of the grid. Due to the relatively short length of the regulatory period, some outputs of innovative projects may not be realized within the time frame imposed. This incentivizes distribution system operators to invest in short-term solutions (e.g. grid extensions) rather than in long-term projects such as demand-response pilots. Furthermore, the revenue base only accounts for the revenues of the distribution system operator and does not consider market-wide positive externalities. The regulatory period also leads to a time delay before new investments are recognized in the revenue base, potentially exposing operators to short-term financial problems. Lastly, as a result of benchmarking techniques R&D expenses are often not considered efficient. For these reasons, it may be necessary to develop additional incentive schemes for smart grid and demand-response projects. Some European countries have already introduced similar initiatives (e.g. Italy and the UK).

Privacy and Consumer Protection

Although there already exists a broad legal framework on privacy and data security at several policy levels (EU, national), there is a lack of sector-specific rules regarding confidentiality and data handling and security in the context of demand-response for residential consumers. This factor may hamper consumer involvement and support. Current regulations are generally designed to support data processing for billing purposes, which typically takes place once a year. Active demand, however, will require a significant increase in processing frequency and data granularity. Regardless of demand-response programs, Belgium is required by EU law to provide consumers with individual meters allowing active management of electricity consumption while also accounting for consumer privacy and data security.

Standardization

Standardization has an important impact on interest in investments and market competitiveness. With an increasing number of technologies being connected to the grid, interoperability is becoming a true challenge. However, there currently exist very few (inter)national smart grid standards. Fortunately, a number of European standardization organizations (CEN, CENELEC and ETSI) are developing smart grid standards, for instance for smart utility meters. Besides standards, there is a need for clear legal definitions of new smart grid concepts, and for streamlining these definitions across different policy levels.

Scientific Publications

- Labeeuw W., Deconinck G. 2014. Potential of Active Demand Reduction With Residential Wet Appliances: A Case Study for Belgium. IEEE Transactions on Smart Grid. Institute of Electrical and Electronics Engineers, early access
- Matthias Strobbe, Koen Vanthournout, Wim Cardinaels and Chris Develder, Large-scale Residential Demand Response ICT Architecture, ISGT Europe 2014, (12-15/10, Istanbul)
- D'Hulst Reinhilde , LV Distribution Network Voltage Control Mechanism: Experimental Tests and Validation, IECON, 2014
- Labeeuw W., Deconinck G. 2013. Residential Electrical Load Model based on Mixture Model Clustering and Markov Models. IEEE Transactions on Industrial Electronics. Institute of Electrical and Electronics Engineers, vol.9 no.3, pp. 1561-1569
- Ruelens F., Demand Response of a Heterogeneous Cluster of Electric Water Heaters Using Batch Reinforcement Learning, PSCC, 2014
- Ruelens F., Aggregated control of thermostatically controlled loads using batch reinforcement learning, PSCC, 2014
- Vanthournout K., A Norm Behavior Based Deterministic Methodology for Demand Response Base Lines, PSCC, 2014
- Rafaël Jahn, Koen Vanthournout, Wim Cardinaels, The Linear residential demand response pilot: balancing wind energy with residential flexibility, 2014 IERE-GDF SUEZ Brussels Workshop "Energy at home"
- Johannes Jargstorf, Kris Kessels, Cedric DeJonghe, Ronnie Belmans, 'Economic Signals in Grid Tariffs for Residential Grid Users', European Energy Market (EEM), 2014 11th International Conference
- Hanspeter Hoschle, Benjamin Dupont, Pieter Vingerhoets, Ronnie Belmans, 'Networked Business Model for Dynamic Pricing in the Electricity Market', European Energy Market (EEM), 2014 11th International Conference
- J. Vandewalle, W. D'Haeseleer 'The Impact of Small Scale Cogeneration on the Gas Demand at Distribution Level, Energy Conversion and Management 78 (2014), 137-150
- Dissertation: Wouter Labeeuw: 'Characterisation and modelling of residential electricity demand', Leuven, Belgium, 9 December 2013
- P. Chittur Ramaswamy, P. Vingerhoets, G. Deconinck, 'Reconfiguring Distribution Grids for More Integration of Distributed Generation', CIRED, Stockholm, Sweden, 10-13 June 2013
- S. Weckx, C. Gonzalez De Miguel, P. Vingerhoets, J. Driesen, 'Phase Switching and Phase Balancing to Cope with a Massive Photovoltaic Penetration', CIRED, 22nd International Conference on Electricity Distribution, Stockholm, Sweden, 10-13 June 2013, Paper 0387
- C. Gonzalez, S. Weckx, N. Efkarpidis, P. Vingerhoets, T. De Rybel, J. Driesen, 'Constrained PV Penetration Level in LV Distribution Networks Based on the Voltage Operational Margin', CIRED, 22nd International Conference on Electricity Distribution, Stockholm, 10-13 June 2013, Paper 0391
- J. Zapata, J. Vandewalle, W. D'haeseleer, 'Applied Thermal Engineering', Applied Thermal Engineering (2013), 1-11
- Sandro Iacovella, Kris Lemkens, P. Vingerhoets, F. Geth, Geert Deconinck, Reinhilde D'hulst, Koen Vanthournout: 'Standalone LV Distribution Network Voltage Control Mechanism', Vienna, 11-13 November 2013
- S. Iacovella, F. Geth, F. Ruelens, N. Leemput, P. Vingerhoets, G. Deconinck, B. Claessens: 'Double-Layered Control Methodology Combining Price Objective and Grid Constraints', Vancouver, Canada, 21-24 October 2013
- Frederik Ruelens, Sam Weckx, Willem Leterme, Stijn Vandael, Bert J. Claessens, Ronnie Belmans: 'Stochastic Portfolio Management of an Electric Vehicles Aggregator Under Price Uncertainty', Copenhagen, 6-9 October 2013
- Claessens Bert, Peak Shaving of a Heterogeneous Cluster of Residential Flexibility Carriers using Reinforcement Learning, ISGT, 2013
- Parvathy Chittur Ramaswamy, Reconfiguring distribution grids for more integration of distributed generation, IECON, 2013
- Ruelens Frederik, Model Predictive Control and Approximate Dynamic Programming for Smart Grid Portfolio Management, ISGT, 2013
- Tant Jeroen, Multiobjective Battery Storage to Improve PV Integration in Residential Distribution Grids, IEEE Transactions on Sustainable Energy, 2013
- S. Iacovella, K. Lemkens, F. Geth, P. Vingerhoets, G. Deconinck, R. D'Hulst, K. Vanthournout: 'Distributed Voltage Control Mechanism in Low-Voltage Distribution Grid Field Test', Copenhagen, Denmark, 6-9 October 2013
- Vencken Y., Labeeuw W., Deconinck G. 2013. Dealing with an Overdose of Photovoltaics at Distribution Level. In IEEE Powertech 2013. Grenoble, 16-20 June 2013, pp. 1-5
- Strobbe M., Verschueren T., Melis S., Mets K., De Turck F., Develder C.: 'Design of a Management Infrastructure for Smart Grid Pilot Data Processing and Analysis', Ghent, Belgium, 27-31 May 2013
- Kris Kessels, Daan Six, Muhajir T. Mekonnen, Benjamin Dupont: 'Feasibility Of Employing Domestic Active Demand For Balancing Wind Power Generation', Stockholm, Sweden, 27-31 May 2013
- K. Lemkens, F. Geth, P. Vingerhoets, G. Deconinck: 'Reducing Overvoltage Problems with Active Power Curtailment –Simulation Results', ISGT, 2013
- Johannes Jargstorf, Kris Kessels, Ronnie Belmans: 'Capacity Based Grid Fees for Residential Customers', Stockholm, Sweden, May 27-31, 2013, 8 pages
- Jeroen Tant, Frederik Geth, Daan Six, Peter Tant, Johan Driesen: 'Multi-Objective Battery Storage to Improve PV Integration in Residential Distribution Grids', January 2013, pp. 182-191
- Labeeuw W., Claessens S., Mets K., Develder C., Deconinck G. 2012. Infrastructure for Collaborating Data-Researchers in a Smart Grid Pilot. In IEEE PES ISGT Europe 2012. Berlin, 14-17 October 2012
- Frederik Geth, Niels Leemput, Juan Van Roy, Jeroen Büscher, Raf Ponnette, Johan Driesen: 'Voltage Droop Charging of Electric Vehicles in a Residential Distribution Feeder', Berlin, Germany October 14-17, 2012 -
- Carlos Gonzalez, Jurgen Geuns, Sam Weckx, Thomas Wijnhoven, Pieter Vingerhoets, Tom De Rybel: 'LV Distribution Network Feeders in Belgium and Power Quality Issues due to Increasing PV Penetration Levels', Berlin, Germany October 14-17, 2012, 8 pages
- J. Jargstorf, K. Vanthournout, T. De Rybel, D. Van Hertem, 'Effect of Demand Response on Transformer Lifetime Expectation', IEEE PES ISGT Europe 2012 3, Berlin, Germany, 14-17 October 2012

- Muhajir Tadesse Mekonnen, Benjamin Dupont, Kristof de Vos, Kris Kessels, Ronnie Belmans: 'Optimizing the Use of Flexible Residential Demand for Balancing Wind Power', Berlin, Germany, October 14-17, 2012
- N. Leemput, F. Geth, B. Claessens, J. Van Roy, R. Ponnette, J. Driesen: 'A Case Study of Coordinated Electric Vehicle Charging for Peak Shaving on a Low Voltage Grid', Berlin, Germany, October 14-17, 2012, 7 pages
- Benjamin Dupont, Jeroen Tant, and Ronnie Belmans: 'Automated Residential Demand Response Based on Dynamic Pricing', Berlin, Germany, October 14-17, 2012
- Johannes Jargstorf, Koen Vanthournout, Tom De Rybel, Dirk Van Hertem: 'Effect of Active Demand on Transformer Lifetime Expectation', Berlin, Germany, October 14-17, 2012, 8 pages
- B. Dupont, P. Vingerhoets, P. Tant, K. Vanthournout, W. Cardinaels, T. De Rybel, E. Peeters, R. Belmans: 'LINEAR Breakthrough Project: Large-Scale Implementation of Smart Grid Technologies in Distribution Grids', Berlin, Germany, October 14-17, 2012, 8 pages
- Jeroen Vandewalle, Juliana Zapata Riveros, Nico Keyaerts, William D'haeseleer: 'The impact of dynamical gas-pricing mechanism on the gas demand at distribution level', Venice, 9-12 September 2012
- Claessens B., Self-Learning DSM for a Heterogeneous Cluster of Devices with Binary Control Actions, ISGT 2012, 2012
- Iacovella S., Lessons learnt from the Linear large-scale energy monitoring field test, YRS, 2012
- Jargstorf J., Effects of Active Demand on Transformer Lifetime Estimation, ISGT, 2012
- Ruelens F., Demand Side management of Electric Vehicles with Uncertainty on Driving Behaviour, ISGT, 2012
- Labeeuw W., Deconinck G. 2012. Customer Sampling in a Smart Grid Pilot. In IEEE PES General Meeting 2012. San Diego, 22-26 July 2012
- J. Vandewalle, N. Keyaerts, W. D'haeseleer: 'The Role of Thermal Storage and Natural Gas in a Smart Energy System', 10-12 May 2012
- S. Iacovella, P. Tant, G. Deconinck: 'Lessons learnt from the Linear large-scale energy monitoring field test', April 16-17, 2012, 5 pages
- Driesen J., Peeters E., Tant P., Belmans R.: 'Introducing Smart Grids in Flanders: the Linear project', 2012; 2 pages
- N. Leemput, J. Van Roy, F. Geth, P. Tant, B. Claessens, J. Driesen: 'Comparative Analysis of Coordination Strategies for Electric Vehicles', Manchester, United Kingdom, December 5-7, 2011, 8 pages
- Juan Van Roy, Niels Leemput, Sven De Breucker, Frederik Geth, Peter Tant, Johan Driesen: 'An Availability Analysis and Energy Consumption Model for a Flemish Fleet of Electric Vehicles', Brussels, Belgium, October 26-28, 2011, 12 pages
- Carlos Gonzalez, Jurgen Geuns, Sam Weckx, Thomas Wijnhoven, Pieter Vingerhoets, Tom De Rybel: 'LV Distribution Network Feeders in Belgium and Power Quality Issues due to Increasing PV Penetration Levels', Frankfurt, Germany, June 6-9, 2011
- Labeeuw W., Deconinck G. 2011. Non-intrusive detection of high power appliances in metered data and privacy issues. In EEDAL. Copenhagen, Denmark, 24-26 May 2011
- Van Roy Juan, Study on the Availability Analysis and Energy Consumption of Electric Vehicles, EEVC2011, 2011
- Frederik Geth, Daan Six, Jeroen Tant, Tom De Rybel, Peter Tant, Johan Driesen: 'Techno-economical and life expectancy modeling of battery energy storage systems', Frankfurt, Germany, June 6-9, 2011, 4 pages
- Benjamin Dupont, Cedric De Jonghe, Kris Kessels, Ronnie Belmans: 'Short-term Consumer Benefits of Dynamic Pricing', Zagreb, Croatia, May 2011, pp 216-221
- J. Van Roy, N. Leemput, S. De Breucker, P. Tant, J. Driesen, 'Study on the Availability Analysis and Energy Consumption of Electric Vehicles', EEVC 2011
- Kevin Mets, Tom Verschueren, Chris Develder, Tine L. Vandoorn, Lieven Vandevelde: 'Integrated Simulation of Power and Communication Networks for Smart Grid Applications', CAMAD 2011
- Daan Six, Johan Desmedt, Dirk Vanhoudt, Johan Van Bael: 'Exploring the flexibility potential of residential heat pumps combined with thermal energy storage for smart grids', CIRED 2011
- Kevin Mets, Tom Verschueren, Filip De Turck, Chris Develder: 'Evaluation of Multiple Design Options for Smart Charging Algorithms', ICC 2011
- Tom Verschueren, Kevin Mets, Matthias Strobbe, Chris Develder, Bart Meersman, Lieven Vandevelde: 'Assessment and mitigation of voltage violations by solar panels in a residential distribution grid'
- Vanthournout K., D'Hulst R., Geysen D., Jacobs G.: 'A Smart Domestic Hot Water Buffer'

Thank You

Linear wishes to thank all these 240+ colleagues for transforming Linear into a cutting-edge real-life demonstration project on demand response:

Reinhart Appels, Dimitris Athanasiadis, Vasiliki Balafouti, Frank Behaegel, Nathalie Belmans, Ronnie Belmans, Bart Beusen, Luc Beyaert, Bart Boesmans, Aline Bogaerts, Lut Bollen, Isabelle Borremans, Ralf Bosch, Bert Callens, Ann Canière, Wim Cardinaels, Koen Casier, Yonghua Cheng, Parvathy Chittur Ramaswamy, Bert Claessens, Sven Claessens, Peter Coenen, Erwin Cornelis, Freek Couttenier, Cathy Crunelle, Theo Daems, Kevin Daems, Jo Das, Sven De Breucker, Pieter De Bruycker, Bart De Caesemaeker, Klaas De Craemer, Jean-Marie De Hoe, Michael de Koster, Lieven De Marez, An De Moor, Fjo De Ridder, Simon De Rijcke, Ian De Ruyver, Tom De Rybel, Lily De Schryver, Erik De Schutter, Johan De Smet, Eef De Vos, Laurent De Vroey, Bert De Vuyst, Johan De Winter, Kevin Daems, Ludo Deckers, Stefan Decoene, Geert Deconinck, Lieven Degroote, Emmanuel Dejaeger, Cedric Dejonghe, Johannes Deleu, Annelies Delnooz, Bram Delvaux, Piet Demeester, Wim Deprez, Frederick Depuydt, Johan Desmedt, Dimitri De Swert, Dirk De Taey, Chris Develder, Kristof Devos, Johan Dewinter, Bram Dewispelaere, Annick Dexters, William D'haeseleer, Reinhilde D'Hulst, Koen Dierckx, Pol Dockx, Johan Driesen, Olivier Ducarme, Benjamin Dupont, Mario Dzamaria, Nikolaos Efkarpidis, Alexander Eisenberg, Hakan Ergun, Jordi Everts, Ben Flamaing, Wim Foubert, Gert Fransen, Egide Gaublumme, Frederik Geth, Jürgen Geuns, Davy Geysen, Jozef Ghijselen, M. Ghijsen, Maarten Gijbers, Virginia Gomez Onate, Carlos Gonzalez de Miguel, Jan Gordebeke, Bert Gysen, Liesbeth Haelterman, Wouter Haerick, Jean Hart, Laurence Hauttekeete, Matthias Hendrickx, Anton Heyman, Frederik Hindryckx, Maarten Hommelberg, Jan Hoogmartens, Hanspeter Hoschle, Tom Hostyn, Sandro Iacovella, Geert Jacobs, Rafaël Jahn, Mark Jansen, Johannes Jargstorf, Luc Jaspers, Ben Juez-Ponce, Kris Kessels, Wouter Labeeuw, Eric Laermans, Kristof Lamont, Bart Lannoo, Malinee Lebegge, Filip Leemans, Niels Leemput, Chris Lefrere, Kris Lemkens, Joris Lemmens, Jo Lenaers, Heidi Lenaerts, Jos Liebens, Ilse Lievens, Kim Loffens, Marijn Maenhoudt, Philip Marivoet, Carolien Martens, Muhajir Mekonnen - Tadesse, Stijn Melis, Pieter Merckx, Kevin Mets, Gianni Manderioli, Guy Meynen, Carlo Mol, Jonathan Moreel, Grietus Mulder, Jelle Nelis, Eric Nens, Jan Neyens, Marleen Nijsten, Thomas Nuytten, Kristof Paredis Kristof, Eefje Peeters, Johny Plessers, Eddy Poncellet, Raf Ponnette, Jef Poortman, Ronald Poosen, Roland Reekmans, Sabrina Remy, Kurt Reynders, Patrick Reyniers, Patrick Robijns, Johan Roef, Frederik Ruelens, Duan Rui, Claude Ruysinck, Hans Rymenants, Wendy Sannen, Kristof Scheepers, Ness Schelkens, Wim Schoofs, Dimitri Schuurman, J. Schwab, Daan Six, Tom Sneyers, Maarten Steenhuyse, Ben Steurs, Marcel Stevens, Randy Stiens, Bart Stiers, Steve Stoffels, Jeroen Stragier, Matthias Strobbe, Catherine Stuckens, Tuur Swimberghe, Muhajir Tadesse Mekonnen, Mathieu Tahon, Jeroen Tant, Peter Tant, Kristof Taveirne, Vincent Thoen, Daniel Tiepermann, Filip Truyens, Stijn Uytterhoeven, Johan Van Bael, Ruth Van Caenegem, Jan Van Cauter, Thierry Van Craenenbroeck, Kris van Daele, Peter-Paul van den Berg, Raf Van den Bossche, Nickey Van den Bulck, Tom Van Eycken, Erik Van Genechten, Luc Van Hoolst, Andy Van Maele, Jan Van Ooteghem, Juan Van Roy, Paul Van Tichelen, Stef Verbraeken, Donald Vanbeveren, Stijn Vandael, Kevin Vandersmissen, Jeroen Vandewalle, Eric Vandewinckel, Dirk Vanevercooren, Chris Vangrunderbeek, Dirk Vanhoudt, Klaartje Vankerckhoven, Ann Vanlommel, Koen Vanthournout, Guy Vekemans, Jeroen Verbeeck, Gert Verbeek, Sofie Verbrugge, Bart Verbruggen, Johan Vercammen, Nick Vercammen, Laurent Vercruysse, Bert Verlinden, Tom Verschueren, Dieter Verslype, Claire Versluys, Johan Verstraeten, Pieter Vingerhoets, Mario Vitale, Dries Vos, Dieter Walckiers, Ingrid Wauthélet, Sam Weckx, Dominique Weyen, Thomas Wijnhoven, Luc Willems, Nancy Wils, Tim Wuyts, Juliana Zapata Riveros, Antony Zegers.



From 2009 to 2015, the Linear project studied ways in which households can tailor their electricity consumption to the amount of solar and wind energy available, both in terms of technology and user interaction. Some key questions that this research was designed to address:

- How do households and industry stand to benefit from a change in behavior?
- How will the costs and benefits be divided among the parties involved?
- Which solutions will provide enough motivation and convenience to prompt a change in behavior?
- To what extent will households be able and willing to change their behavior?

Twenty partners joined hands to support Linear, or 'Local Intelligent Networks and Energy Active Regions'. It was born of a partnership between research institutions including EnergyVille (KU Leuven, VITO & imec) and iMinds, industry and the Government of Flanders.

Linear was the source for many scientific publications, as well as lay information on smart grids. The project ended as a finalist in the ISGAN Award of 2013, earning global recognition.